

Contents

| | |
|--|-----------|
| Chapter 1 Safety Instruction | 1 |
| 1.1 Safety Claim | 1 |
| 1.2 Safety Instruction | 1 |
| 1.3 Electromagnetic Interference Prevention..... | 3 |
| Chapter 2 Overview..... | 4 |
| 2.1 Introduction..... | 4 |
| 2.2 Key Feature..... | 4 |
| Chapter 3 Appearance | 5 |
| Chapter 4 Connector and Cable..... | 11 |
| 4.1 Device with Fast Ethernet Interface | 11 |
| 4.2 Device with USB Interface..... | 18 |
| 4.3 Device with RS-232 Interface..... | 22 |
| 4.4 IO Box | 22 |
| Chapter 5 Installation | 24 |
| 5.1 Installation Preparation..... | 24 |
| 5.2 Install Device | 24 |
| Chapter 6 I/O Electrical Feature and Wiring | 26 |
| 6.1 I/O Electrical Feature and Wiring of Type V Device | 26 |
| 6.1.1 Opto-isolated Input Circuit..... | 26 |
| 6.1.2 Opto-isolated Output Circuit..... | 27 |
| 6.1.3 Input Signal Wiring | 28 |
| 6.1.4 Output Signal Wiring | 29 |
| 6.2 I/O Electrical Feature and Wiring of Other Devices | 30 |
| 6.2.1 Non-isolated Input Circuit | 31 |
| 6.2.2 Non-isolated Output Circuit | 32 |
| 6.2.3 Bi-directional I/O Circuit..... | 33 |
| 6.2.4 Input Signal Wiring | 34 |
| 6.2.5 Output Signal Wiring | 38 |
| 6.3 RS-232 Serial Port | 39 |

| | |
|---|-----------|
| Chapter 7 Device Connection | 41 |
| 7.1 Install Client Software | 41 |
| 7.2 Set PC Environment | 42 |
| 7.2.1 Turn off Firewall for Network Device | 42 |
| 7.2.2 Set PC Network for Network Device | 42 |
| 7.2.3 Check USB Drive for USB Device..... | 43 |
| 7.3 Set Device Network and Connect to Client Software | 44 |
| Chapter 8 Basic Operation | 45 |
| 8.1 Client Software Layout | 45 |
| 8.2 Basic Operation | 46 |
| Chapter 9 Device Settings..... | 49 |
| 9.1 Feature Tree Introduction | 49 |
| 9.2 Code Reading Mode Settings | 50 |
| 9.3 Image Quality Settings | 51 |
| 9.3.1 Set Image | 52 |
| 9.3.2 Set Polling | 53 |
| 9.3.3 Set Light Source..... | 56 |
| 9.3.4 Set Smart Tune..... | 57 |
| 9.3.5 Set Focus..... | 59 |
| 9.3.6 Set Self-Adaptive Adjustment | 63 |
| 9.3.7 Set Test Pattern..... | 64 |
| 9.4 Code Algorithm Settings | 65 |
| 9.4.1 Add Code | 65 |
| 9.4.2 Set Code Reading ROI | 65 |
| 9.4.3 Set Algorithm Parameter | 67 |
| 9.4.4 Set Code Quality Evaluation..... | 71 |
| 9.4.5 Set Code Score | 73 |
| 9.5 Line Mode Settings | 74 |
| 9.6 Signal Input Settings | 75 |
| 9.6.1 Set Trigger Mode..... | 75 |
| 9.6.2 Enable Internal Trigger Mode..... | 75 |
| 9.6.3 Enable External Trigger Mode..... | 75 |

| | |
|---|-----|
| 9.6.4 Stop Trigger | 79 |
| 9.7 Signal Output Settings | 83 |
| 9.7.1 Select Output Signal..... | 83 |
| 9.7.2 Enable Line Inverter..... | 83 |
| 9.7.3 Set Event Source | 84 |
| 9.7.4 Set Buzzer | 86 |
| 9.8 Communication Settings..... | 87 |
| 9.8.1 Set SmartSDK | 87 |
| 9.8.2 Set TCP Client..... | 88 |
| 9.8.3 Set Serial | 88 |
| 9.8.4 Set FTP..... | 88 |
| 9.8.5 Set TCP Server..... | 89 |
| 9.8.6 Set Profinet | 89 |
| 9.8.7 Set MELSEC/SLMP | 89 |
| 9.8.8 Set Ethernet/IP | 90 |
| 9.8.9 Set ModBus..... | 91 |
| 9.8.10 UDP | 91 |
| 9.8.11 Fins..... | 92 |
| 9.8.12 USB | 93 |
| 9.9 Data Processing Settings..... | 93 |
| 9.9.1 Set Filter Rule | 93 |
| 9.9.2 Data Processing Settings | 97 |
| 9.10 Set Multicast..... | 99 |
| 9.11 Main-Sub Networking | 100 |
| 9.12 Contrast Control Settings | 102 |
| 9.13 Statistics Information..... | 104 |
| 9.14 Diagnose Event Report..... | 105 |
| 9.15 User Set Customization | 106 |
| Chapter 10 Setting Codes | 108 |
| 10.1 Introduction..... | 108 |
| 10.2 Enable/Disable Setting Codes..... | 108 |
| 10.3 Set Setting Codes of Code Type | 109 |

| | |
|---|------------|
| 10.4 Set Setting Codes of Code Color | 112 |
| 10.5 Set Setting Codes of Code Reading Quantity | 113 |
| 10.6 Set Setting Codes of Data Processing..... | 115 |
| 10.7 Set Setting Codes of Aiming System..... | 117 |
| 10.8 Set Setting Codes of Light Source | 118 |
| 10.9 Set Setting Codes of Buzzer..... | 118 |
| 10.10 Set Setting Codes of USB Communication | 119 |
| 10.11 Set Setting Codes of Serial Port..... | 120 |
| 10.12 Set Setting Codes of Sending Device Information | 121 |
| 10.13 Set Setting Codes of Trigger..... | 122 |
| 10.14 Set Setting Codes of Management | 123 |
| Chapter 11 Device Maintenance..... | 125 |
| 11.1 Update Firmware | 125 |
| 11.2 Set Time..... | 125 |
| 11.3 Enable Device Auto Work..... | 126 |
| 11.4 Reboot Device..... | 127 |
| Chapter 12 FAQ (Frequently Asked Question) | 128 |
| 12.1 Why there is no device listed after I run the IDMVS client software? | 128 |
| 12.2 Why the image is very dark? | 128 |
| 12.3 Why the image's frame rate is very low in the live view? | 128 |
| 12.4 Why there is no image in the live view?..... | 129 |
| Appendix A ASCII Table | 130 |

Chapter 1 Safety Instruction

The safety instructions are intended to ensure that the user can use the device correctly to avoid danger or property loss. Read and follow these safety instructions before installing, operating and maintaining the device.

1.1 Safety Claim

- To ensure personal and device safety, when installing, operating, and maintaining the device, follow the signs on the device and all safety instructions described in the manual.
- The note, caution and danger items in the manual do not represent all the safety instructions that should be observed, but only serve as a supplement to all the safety instructions.
- The device should be used in an environment that meets the design specifications, otherwise it may cause malfunctions, and malfunctions or component damage caused by non-compliance with relevant regulations are not within the scope of the device's quality assurance.
- Our company will not bear any legal responsibility for personal safety accidents and property losses caused by abnormal operation of the device.

1.2 Safety Instruction

Caution

- The laser safety class of some models of the device belongs to class 2. It is prohibited to use optical telescope to observe the device. It is forbidden to look directly at the window of the laser module of the device to avoid irreversible damage to the eyes.

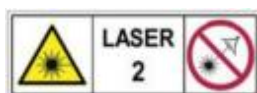

- Do not install the device if it is found that the device and accessories are damaged, rusted, water ingress, model mismatch, missing parts, etc., when unpacking.
- Avoid storage and transportation in places such as water splashing and rain, direct sunlight, strong electric fields, strong magnetic fields, and strong vibrations.
- Avoid dropping, smashing or vigorously vibrating the device and its components.
- It is forbidden to install the indoor device in an environment where it may be exposed to water or other liquids. If the device is damp, it may cause fire and electric shock hazard.
- Place the device in a place out of direct sunlight and ventilation, away from heat sources such as heaters and radiators.
- In the use of the device, you must be in strict compliance with the electrical safety regulations of the nation and region.
- Use the power adapter provided by the official manufacturer. The power adapter must

meet the Limited Power Source (LPS) requirements. For specific requirements, please refer to the device's technical specifications.

- It is strictly forbidden to wire, maintain, and disassemble the device is powered on. Otherwise, there is a danger of electric shock.
- Make sure that the device is installed in good condition, the wiring is firm, and the power supply meets the requirements before powering on the device.
- Looking directly at the device may cause harm to the eyes. Protective measures like wearing protective glasses should be taken in the process of installation, maintenance and debugging.
- If the device emits smoke, odor or noise, please turnoff the power and unplug the power cord immediately, and contact the dealer or service center in time.
- It is strictly forbidden for non-professional technicians to detect signals during device operation, otherwise it may cause personal injury or device damage.
- Avoid aiming the lens at strong light such as lighting, sunlight, or laser beams, etc., otherwise the image sensor will be damaged.
- It is forbidden to touch the image sensor directly. If necessary, please moisten a soft clean cloth with alcohol and gently wipe off the dust. When the device is not in use, please add a dust cover to protect the image sensor.
- If the device does not work properly, please contact your dealer or the nearest service center. Never attempt to disassemble the device yourself. We shall not assume any responsibility for problems caused by unauthorized repair or maintenance.
- Caution: If the device has battery, risk of explosion if battery is replaced by an incorrect type. Dispose of used batteries according to the instructions.
- Please dispose of the device in strict accordance with the relevant national or regional regulations and standards to avoid environmental pollution and property damage.

Note

- Check whether the device's package is in good condition, whether there is damage, intrusion, moisture, deformation, etc. before unpacking.
- Check the surface of the device and accessories for damage, rust, bumps, etc. when unpacking.
- Check whether the quantity and information of the device and accessories are complete after unpacking.
- Store and transport the device according to the storage and transport conditions of the device, and the storage temperature and humidity should meet the requirements.
- It is strictly prohibited to transport the device in combination with items that may affect or damage the device.
- The device should not be placed with exposed flame sources, such as lighted candles.
- Please read the manual and safety instructions carefully before installing the device.
- Quality requirements for installation and maintenance personnel:
 - Qualification certificate or working experience in weak current system installation and maintenance, and relevant working experience and qualifications. Besides, the personnel must possess the following knowledge and operation skills.
 - The basic knowledge and operation skills of low voltage wiring and low voltage electronic circuit connection.

- The ability to comprehend the contents of this manual.
- Do not contact the device with strong acids, alkalis, oils, greases or organic solutions such as thinners.
- Do not expose the device directly to flashlights, high-frequency switch lighting devices, or to sunlight, which may affect the performance.
- Do not impose pressure on the cable end of the device, such as forced bending, pulling, etc.

1.3 Electromagnetic Interference Prevention

- Make sure that the shielding layer of cables is intact and 360° connected to the metal connector when using shielded cables.
- Do not route the device together with other equipment (especially servo motors, high-power devices, etc.), and control the distance between cables to more than 10 cm. Make sure to shield the cables if unavoidable.
- The control cable of the device and the power cable of the industrial light source must be wired separately to avoid bundled wiring.
- The power cable, data cable, signal cable, etc. of the device must be wired separately. Make sure to ground them if the wiring groove is used to separate the wiring and the wiring groove is metal.
- During the wiring process, evaluate the wiring space reasonably, and do not pull the cables hard, so as not to damage the electrical performance of the cables.
- If the device is powered on and off frequently, it is necessary to strengthen the voltage isolation, and consider adding a DC/DC isolation power supply module between the device and the adapter.
- Use the power adapter to supply power to the device separately. If centralized power supply is necessary, make sure to use a DC filter to filter the power supply of the device separately before use.
- The unused cables of the device must be insulated.
- When installing the device, if you cannot ensure that the device itself and all equipment connected to the device are well grounded, you should isolate the device with an insulating bracket.
- To avoid the accumulation of static electricity, ensure that other equipment (such as machines, internal components, etc.) and metal brackets onsite are properly grounded.
- Make sure that the connector metal barrier of the device is well connected to the PC and other chassis, and if necessary, copper foil should be used to enhance the grounding effect.
- During the installation and use of the device, high voltage leakage must be avoided.
- Use a figure-eight bundle method if the device cable is too long.
- When connecting the device and metal accessories, they must be connected firmly to maintain good conductivity.
- Use a shielded network cable to connect to the device. If you use a self-made network cable, make sure that the shielding shell at the aviation head is well connected to the aluminum foil or metal braid of the shielding cable.

Chapter 2 Overview

2.1 Introduction

With functions of image acquisition, code recognition and output, the ID2000 series industrial code reader can read different types of 1D codes and 2D codes. It adopts compact design and is small in size. The device is applicable to consumer electronics, food and medicine, automobile spare parts, and other industries.

The device uses sensors and optical elements to obtain images of the measured object, which is achieved via the built-in deep learning code reading algorithm. The device also supports outputting the detection result via different communication modes.

2.2 Key Feature

- Compact design and small in size.
- Adopts code reading algorithm to read different types of 1D codes and 2D codes.
- Provides good robustness to read codes with spots, defects and low contrast ratio.
- Adopts laser-aiming light to help aim codes.
- Adopts buzzer and status indicator for prompting the device's operation status.
- Adopts multiple IO interfaces and plug-in power interface.
- Supports multiple communication protocols, including TCP, Serial, FTP, Profinet, etc.

Note

- The specific functions may differ by device models.
 - Refer to the device's specifications for specific parameters.
-

Chapter 3 Appearance

 **Note**

Appearance here is for reference only. Refer to the device's specification for detailed dimension information.

Refer to the table and figures below for the information and appearance of different device models.

Table 3-1 Device Description

| Figure | Device Description |
|-----------------------------|---|
| Figure 3-1, Type I Device | The device does not have a focus knob, but it supports adjusting focus via its solid vari focal lens. |
| Figure 3-2, Type II Device | The device is a vari focal device that supports adjusting focus manually via its focus knob. Its focal length is short. |
| Figure 3-3, Type III Device | The device is a vari focal device that supports adjusting focus manually via its focus knob. Its focal length is long. |
| Figure 3-4, Type IV Device | The device has ac-mount lens mount. |
| Figure 3-5, Type V Device | The device is a fixed focal device whose focus cannot be adjusted. |
| Figure 3-6, Type VI Device | The device is a fixed focal device whose focus cannot be adjusted. |
| Figure 3-7, Type VII Device | The device is a fixed focal device whose focus cannot be adjusted. It adopts compact design and is small in size. |

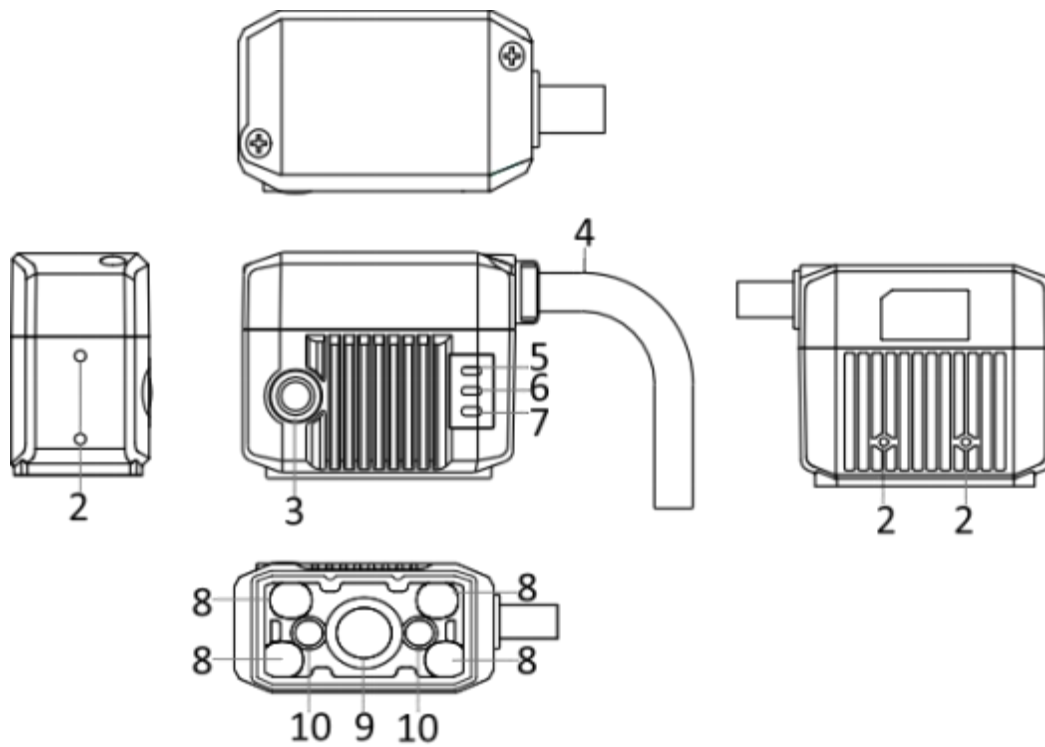

Figure 3-1 Appearance (Type I)

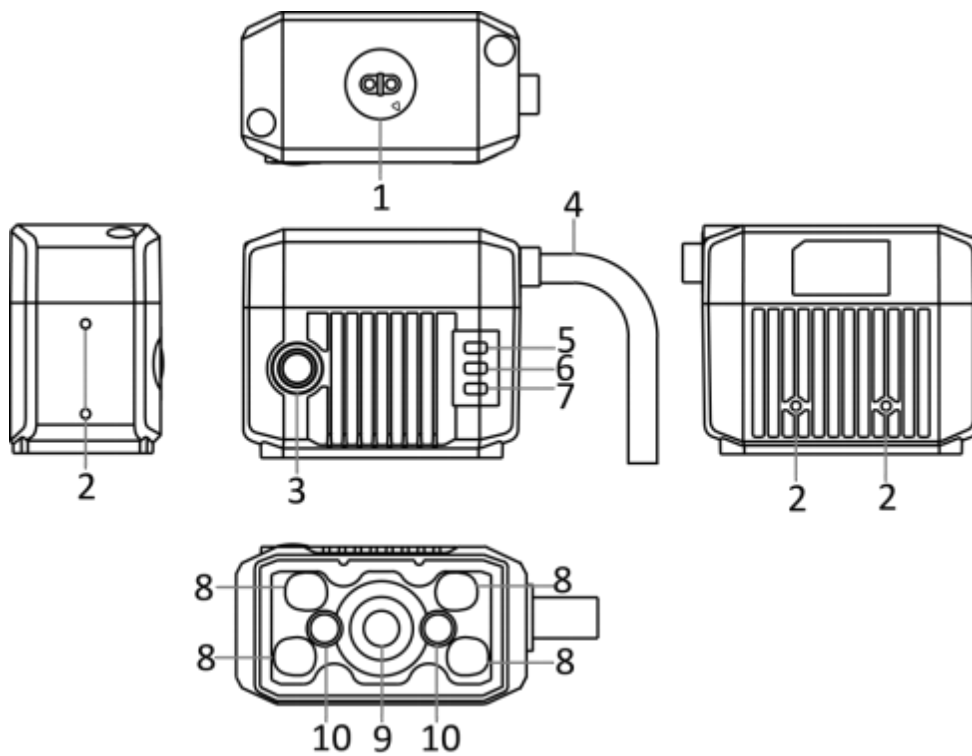

Figure 3-2 Appearance (Type II)

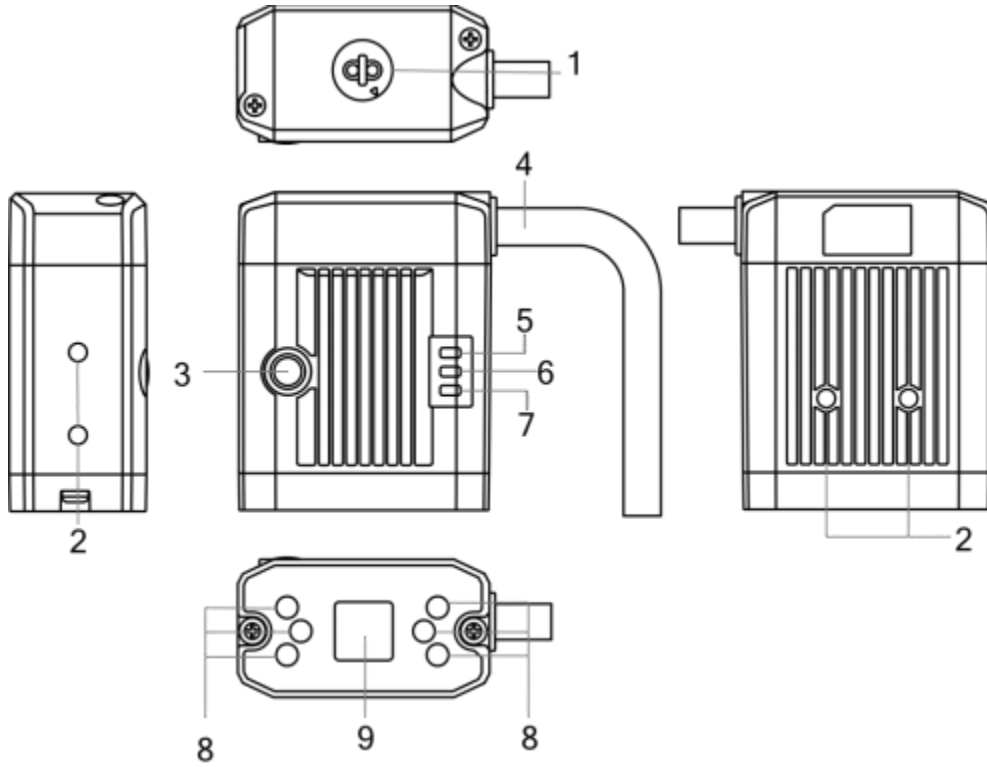

Figure 3-3 Appearance (Type III)

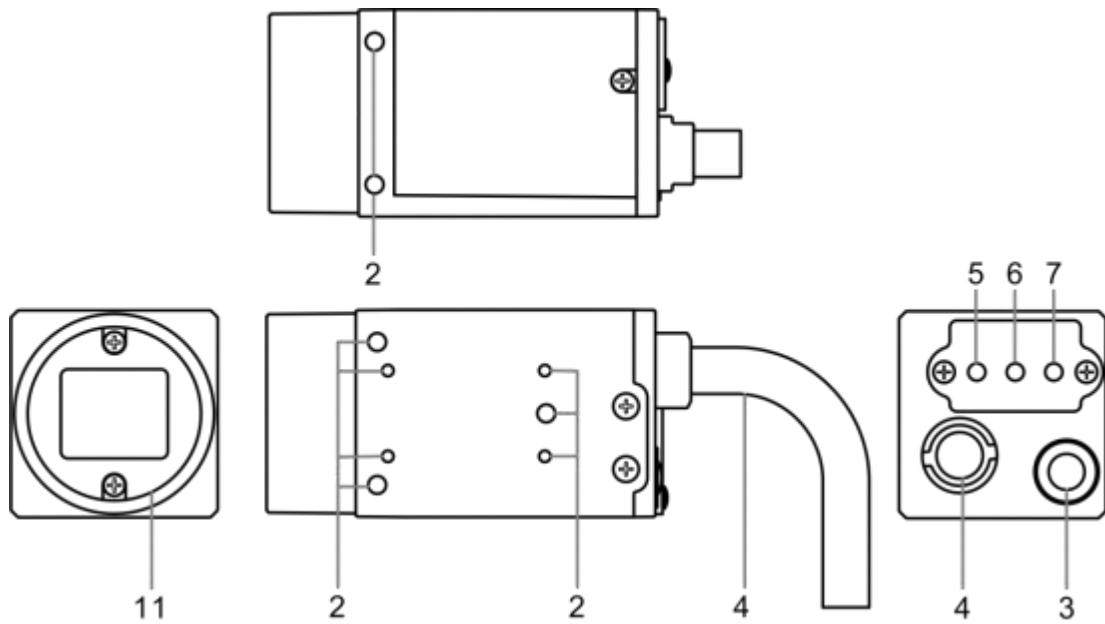

Figure 3-4 Appearance (Type IV)

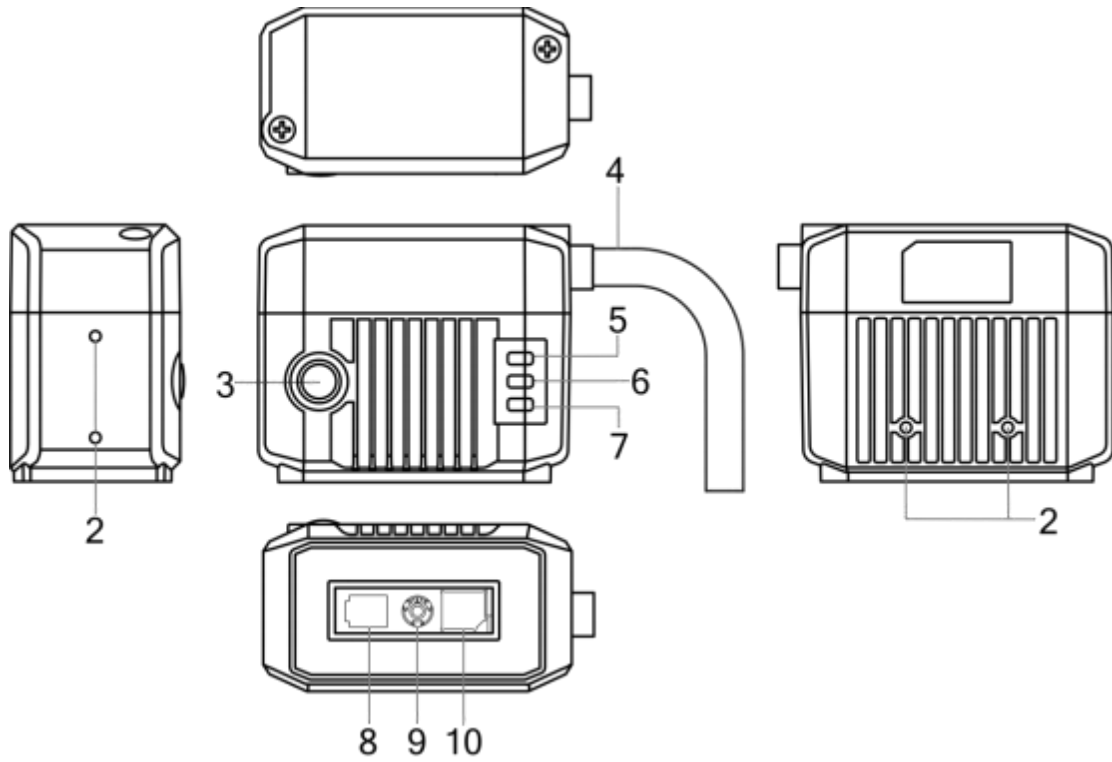

Figure 3-5 Appearance (Type V)

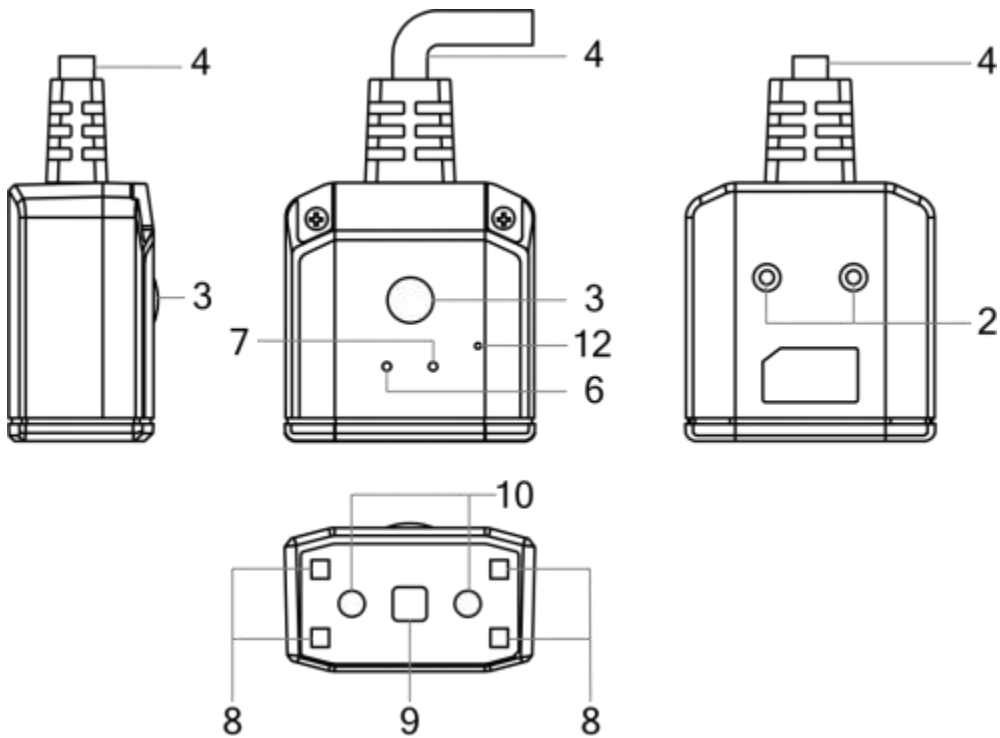

Figure 3-6 Appearance (Type VI)

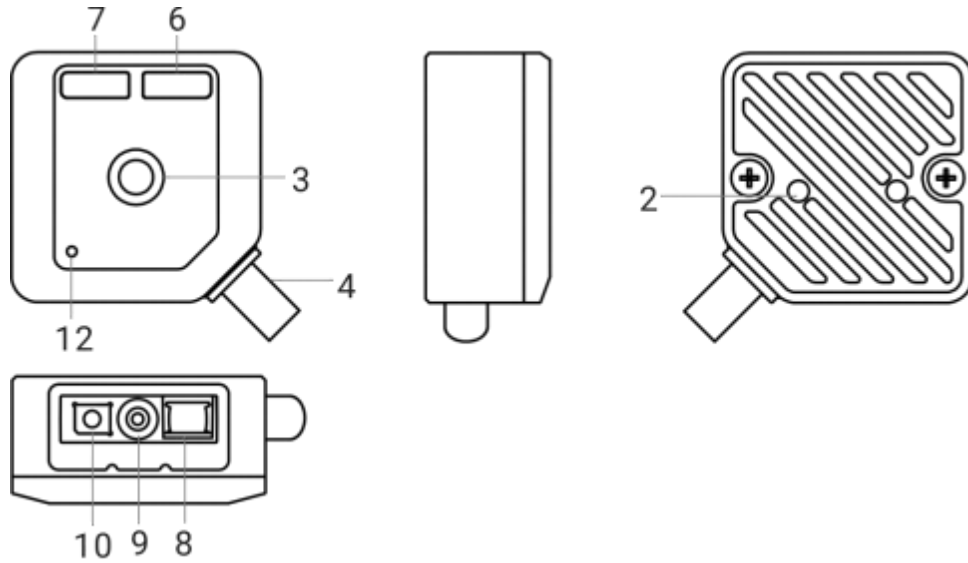





Figure 3-7 Appearance (Type VII)

Table 3-1 Component Description

| No. | Name | Description |
|-----|------------------|--|
| 1 | Focus Knob | It is used to adjust focal length manually. |
| 2 | Screw Hole | It is used to fix the device to the installation position. |
| 3 | Button | <p>It is used to trigger the device or execute smart tune process.</p> <ul style="list-style-type: none"> ● Trigger button: When the device is in trigger mode, press the button and the device triggers once. ● Smart tune button: Hold the button for 3 sec and the device starts smart tune. Hold the button for 3 sec again during smart tune process, and the adjustment will be cancelled. <p>Note The specific function of the button may differ by device models.</p> |
| 4 | SR Cable | <p>SR cable connector provides power, I/O, Ethernet, and serial port.</p> <p>Note The specific function of the SR cable may differ by device models.</p> |
| 5 | LNK Indicator | <p>It is a network status indicator. The indicator is flashing green when the network transmission is normal. Otherwise, it is unlit.</p> <p>Note Type VI and type VII devices do not have a LNK indicator.</p> |
| 6 | Status Indicator | <ul style="list-style-type: none"> ● It is in red color when the device starts up or operation error occurs. ● It is unlit when the device operates normally without reading codes. |

| No. | Name | Description |
|-----|---------------|--|
| | | <ul style="list-style-type: none"> It is in green color lasting 0.5 s when the device reads codes successfully, is solid green when the device reads codes continuously, and is in red color when the device does not read codes. <p> Note The specific function of the status indicator may differ by device models.</p> |
| 7 | PWR Indicator | It is a power indicator. The indicator is red during the device's power-on process. After the device is powered on, the indicator is green. |
| 8 | Light Source | It is the LED light source used to provide light when the device acquires images.  Note The light source color is different by device models. |
| 9 | Sensor | It is used to acquire images. |
| 10 | Aiming Light | It helps to indicate the field of view and aim targets. |
| 11 | Lens Mount | It is used to install the lens. |
| 12 | Buzzer | The buzzer beeps three times when the device is powered on, beeps twice when the device reads setting codes successfully, and beeps once when the device reads codes successfully.  Note Only type VI and type VII devices have a buzzer. |

Chapter 4 Connector and Cable

This section introduces the device's connector, including fast Ethernet interface, USB interface and RS-232 interface, and the supplied cable in the package.

 **Note**

The device's connector and connector pin definitions may differ by device models.

4.1 Device with Fast Ethernet Interface

Device with fast Ethernet interface includes type I, type II, type III, type IV, type V, and type VI devices.

Type I, Type II, Type III, and Type IV Devices

Type I, type II, type III, and type IV devices have a 17-pin M12 connector. Refer to the figure and table below for details.

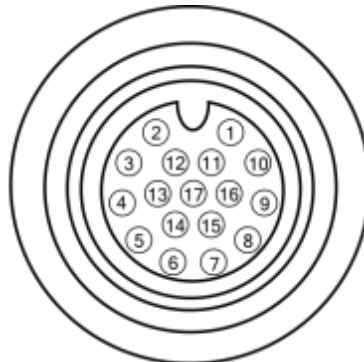

Figure 4-1 17-Pin M12 Connector

Table 4-1 Pin Definitions (Type I, Type II, Type III and Type VI Devices)

| No. | Signal | I/O Signal Source | Description | Supplied Cable |
|-----|----------|----------------------------|--------------------------------------|------------------------|
| 1 | DC_PWR | -- | Direct current power supply positive | 8-pin terminal |
| 2 | GND | Line 0/1/2/3-signal ground | Direct current power supply negative | 8-pin terminal |
| 3 | Reserved | | | |
| 4 | RS232_TX | -- | RS-232 serial port output | DB9 female serial port |
| 5 | RS232_RX | -- | RS-232 serial port input | DB9 female serial port |

| No. | Signal | I/O Signal Source | Description | Supplied Cable |
|-----|----------|--------------------------------|---|----------------------------|
| 6 | MDI0+ | -- | Fast Ethernet signal MDI0+ | RJ45 Ethernet connector |
| 7 | MDI1- | -- | Fast Ethernet signal MDI1- | RJ45 Ethernet connector |
| 8 | GPIO2 | Line 2+ | Non-isolated Input | 8-pin terminal |
| 9 | GND | Line 0/1/2/3- signal ground | Direct current power supply negative | 8-pin terminal |
| 10 | GPIO3 | Line 3+ | Non-isolated Output | 8-pin terminal |
| 11 | GND | -- | Direct current power supply negative | 8-pin terminal |
| 12 | Reserved | | | |
| 13 | Reserved | | | |
| 14 | MDI0- | -- | Fast Ethernet signal MDI0- | RJ45 Ethernet connector |
| 15 | MDI1+ | -- | Fast Ethernet signal MDI1+ | RJ45 Ethernet connector |
| 16 | GPIO0 | Line 0+ | It can be configured as input or output, and is input by default. | 8-pin terminal |
| 17 | GPIO1 | Line 1+ | It can be configured as input or output, and is input by default. | 8-pin terminal |

Type V Devices

The type V device also has a 17-pin M12 connector. Refer to the figure and table below for details.

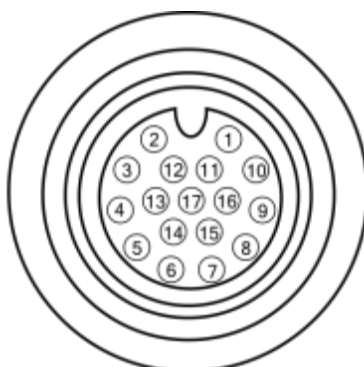

Figure 4-2 17-Pin M12 Connector

Table 4-2 Pin Definitions (Type V Device)

| No. | Signal | I/O Signal Source | Description | Supplied Cable |
|-----|-----------|---------------------------|--------------------------------------|-------------------------|
| 1 | DC_PWR | -- | Direct current power supply positive | 8-pin terminal |
| 2 | OUT_COM | LineOut 0/1 signal ground | Output common port | 8-pin terminal |
| 3 | Reserved | | | |
| 4 | RS232TX | -- | RS-232 serial port output | DB9 female serial port |
| 5 | RS232RX | -- | RS-232 serial port input | DB9 female serial port |
| 6 | MDI0+ | -- | Fast Ethernet signal MDI0+ | RJ45 Ethernet connector |
| 7 | MDI1- | -- | Fast Ethernet signal MDI1- | RJ45 Ethernet connector |
| 8 | OPTO_OUT0 | LineOut 0 signal line | Opto-isolated output 0 | 8-pin terminal |
| 9 | IN_COM | LineIn 0/1 signal ground | Input common port | 8-pin terminal |
| 10 | OPTO_OUT1 | LineOut 1 signal line | Opto-isolated output 1 | 8-pin terminal |
| 11 | GND | -- | Direct current power supply negative | 8-pin terminal |
| 12 | Reserved | | | |

| No. | Signal | I/O Signal Source | Description | Supplied Cable |
|-----|----------|----------------------|----------------------------|-------------------------|
| 13 | Reserved | | | |
| 14 | MDI0- | -- | Fast Ethernet signal MDI0- | RJ45 Ethernet connector |
| 15 | MDI1+ | -- | Fast Ethernet signal MDI1+ | RJ45 Ethernet connector |
| 16 | OPTO_IN0 | LineIn 0 signal line | Opto-isolated input 0 | 8-pin terminal |
| 17 | OPTO_IN1 | LineIn 1 signal line | Opto-isolated input 1 | 8-pin terminal |

For type I, type II, type III, type IV, and type V devices, you should use the supplied 17-pin cable below to wire them. The cable has a DB9 female serial port connector that corresponds to 4th and 5th pins of the 17-pin M12 connector, and a RJ45 connector that corresponds to 6th, 7th, 14th, and 15th pins of the 17-pin M12 connector. Others lines of the 17-pin cable have been made into an 8-pin terminal.

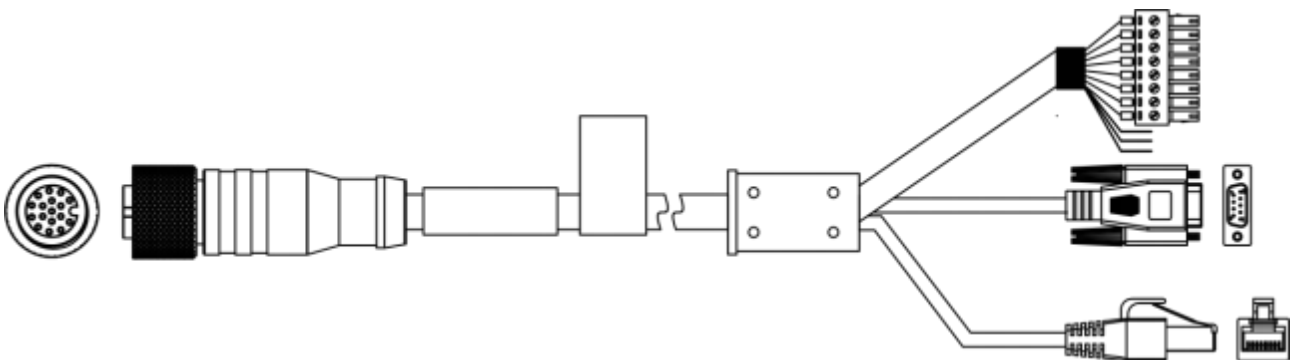

Figure 4-3 17-Pin Cable for Type I, Type II, Type III, Type IV and Type V Devices

The 8-pin terminal is shown below. Refer to table 4-3 for the type I, type II, type III and type IV devices' pin definitions, and refer to table 4-4 for the type V device's pin definitions.

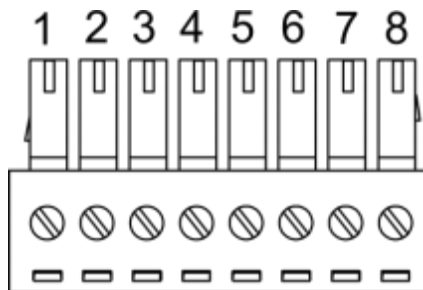

Figure 4-4 8-Pin Terminal

Table 4-3 8-Pin Terminal Definitions (Type I, Type II, Type III and Type IV Device)

| No. | Signal | Description | Cable Color |
|-----|----------|---|-------------|
| 1 | DO_5 | -- | Brown |
| 2 | DO_4 | -- | Blue |
| 3 | DO_3 | Non-isolated Output | Brown/White |
| 4 | DI_2 | Non-isolated Input | Blue/White |
| 5 | DI_1 | It can be configured as input or output, and is input by default. | White |
| 6 | DI_0 | It can be configured as input or output, and is input by default. | Gray |
| 7 | GND | Direct Current Power Supply Negative | Black |
| 8 | POWER_IN | Direct Current Power Supply Positive | Red |

Table 4-4 8-Pin Terminal Definitions (Type V Device)

| No. | Signal | Description | Cable Color |
|-----|----------|--------------------------------------|-------------|
| 1 | OUT_COM | Output Common Port | Brown |
| 2 | IN_COM | Input Common Port | Blue |
| 3 | GPIO3 | Opto-isolated Output 1 | Brown/White |
| 4 | GPIO2 | Opto-isolated Output 0 | Blue/White |
| 5 | GPIO1 | Opto-isolated Input 1 | White |
| 6 | GPIO0 | Opto-isolated Input 0 | Gray |
| 7 | GND | Direct Current Power Supply Negative | Black |
| 8 | POWER_IN | Direct Current Power Supply Positive | Red |

 **Note**

The supplied 17-pin cable may differ by device models.

Type VI Device

Type VI device has a DB15 connector. Refer to the figure and table below for connector pin definitions.

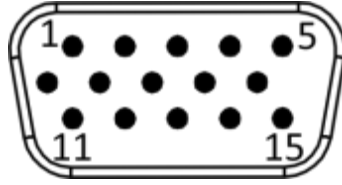

Figure 4-5 DB15 Connector

Table 4-5 Pin Definitions (Type VI Device)

| No. | Signal | I/O Signal Source | Description | Supplied Cable |
|-----|----------|-------------------|--------------------------------------|-------------------------|
| 1 | POWER_IN | -- | Direct current power supply positive | DB9 male serial port |
| 2 | RS232_TX | -- | RS-232 serial port output | DB9 male serial port |
| 3 | RS232_RX | -- | RS-232 serial port input | DB9 male serial port |
| 4 | GND | Line 0/1/2/3- | Direct current power supply negative | 6-pin terminal |
| 5 | OPTO_IN0 | LineIn 0+ | Non-isolated input 0 | 6-pin terminal |
| 6 | TX+ | -- | Fast Ethernet signal TX+ | RJ45 Ethernet connector |
| 7 | RX- | -- | Fast Ethernet signal RX- | RJ45 Ethernet connector |
| 8 | OPTO_OUT | LineOut 2+ | Non-isolated output 2 | 6-pin terminal |
| 9 | Reserved | | | |
| 10 | IO_2 | LineOut 3+ | Non-isolated output 3 | 6-pin terminal |
| 11 | Reserved | | | |
| 12 | Reserved | | | |
| 13 | IO_1 | LineIn 1+ | Non-isolated input 1 | 6-pin terminal |
| 14 | TX- | -- | Fast Ethernet signal TX+ | RJ45 Ethernet connector |
| 15 | RX+ | -- | Fast Ethernet signal RX- | RJ45 Ethernet connector |

For type VI device, you should use the supplied cable, as shown below, to wire the device. The cable has a DB9 female serial port that corresponds to 1st, 2nd, and 3rd pins of the device's DB15 connector, and a 6-pin terminal that corresponds to 4th, 5th, 8th, 10th, and 13th pins of the device's DB15 connector, and a RJ45 connector that corresponds to 6th, 7th, 14th, and 15th pins of the device's DB15 connector.

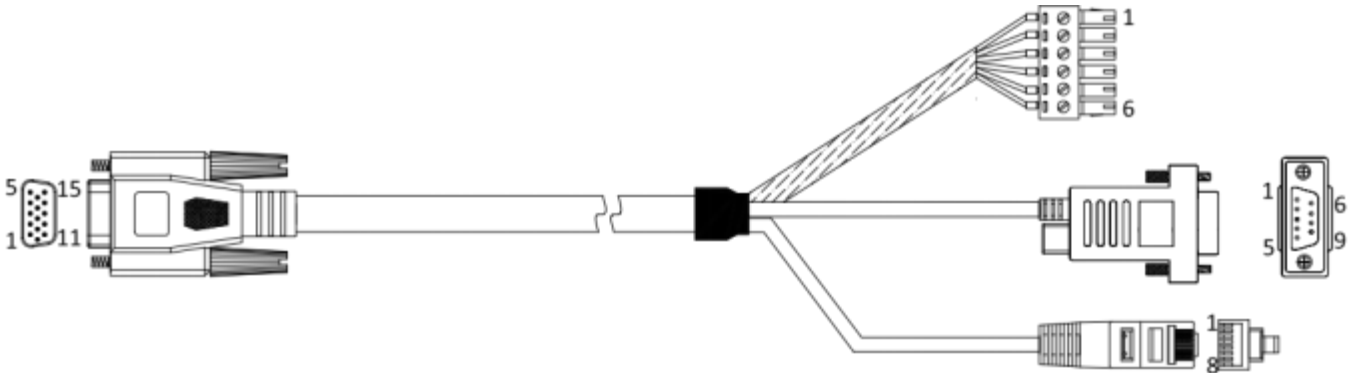

Figure 4-6 Cable for Type VI Device

Refer to the figure and table below for the pin definitions of the 6-pin terminal.

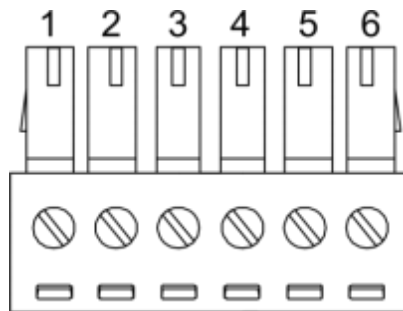

Figure 4-7 6-Pin Terminal

Table 4-6 Pin Definitions (6-Pin Terminal)

| No. | Signal | Description | Cable Color |
|-----|-----------|--------------------------------------|-------------|
| 1 | LINEIN 0 | Non-isolated Input 0 | Blue |
| 2 | LINEOUT 2 | Non-isolated Output 2 | Gray |
| 3 | LINEOUT 3 | Non-isolated Output 3 | Brown |
| 4 | LINEIN 1 | Non-isolated Input 1 | Purple |
| 5 | GND | Direct Current Power Supply Ground | Black |
| 6 | VCC | Direct Current Power Supply Positive | Red |

⚠ Caution

You cannot use DB9 female serial port and VCC to power the device at the same time. Otherwise, damaging to power supply may occur.

4.2 Device with USB Interface

Device with USB interface includes type I device to type VII device.

Type I to Type V Devices

Type I, type II, type III, type IV and type V devices all have a 17-pin M12 connector. Refer to the figure and table below for connector pin definitions.

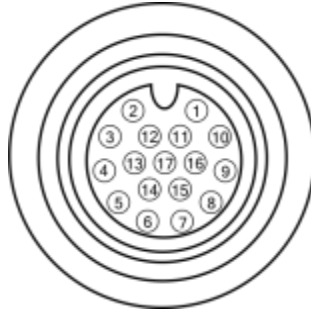

Figure 4-8 17-Pin M12 Connector

Table 4-7 Pin Definitions (Type I to Type V Devices)

| No. | Signal | I/O Signal Source | Description | Supplied Cable |
|-----|-----------|---------------------------|--------------------------------------|------------------------|
| 1 | DC_PWR | -- | Direct current power supply positive | 8-pin terminal |
| 2 | OUT_COM | LineOut 0/1 signal ground | Output common port | 8-pin terminal |
| 3 | USB_DM | -- | USB DM signal | USB interface |
| 4 | RS232TX | -- | RS-232 serial port output | DB9 female serial port |
| 5 | RS232RX | -- | RS-232 serial port input | DB9 female serial port |
| 6 | Reserved | | | |
| 7 | Reserved | | | |
| 8 | OPTO_OUT0 | LineOut 0 signal line | Opto-isolated output 0 | 8-pin terminal |
| 9 | IN_COM | LineIn 0/1 signal ground | Input common port | 8-pin terminal |
| 10 | OPTO_OUT1 | LineOut 1 signal line | Opto-isolated output 1 | 8-pin terminal |
| 11 | GND | -- | Direct current power | 8-pin terminal |

| No. | Signal | I/O Signal Source | Description | Supplied Cable |
|-----|----------|----------------------|-----------------------|----------------|
| | | | supply negative | |
| 12 | USB_DP | -- | USB DP signal | USB interface |
| 13 | Reserved | | | |
| 14 | Reserved | | | |
| 15 | Reserved | | | |
| 16 | OPTO_IN0 | LineIn 0 signal line | Opto-isolated input 0 | 8-pin terminal |
| 17 | OPTO_IN1 | LineIn 1 signal line | Opto-isolated input 1 | 8-pin terminal |

For type I to type V devices with USB interface, you should use the supplied 17-pin cable below to wire them. The cable has a DB9 female serial port connector that corresponds to 4th and 5th pins of the 17-pin M12 connector, and a USB interface that corresponds to 3th and 12th pins of the 17-pin M12 connector. Others lines of the 17-pin cable have been made into an 8-pin terminal.

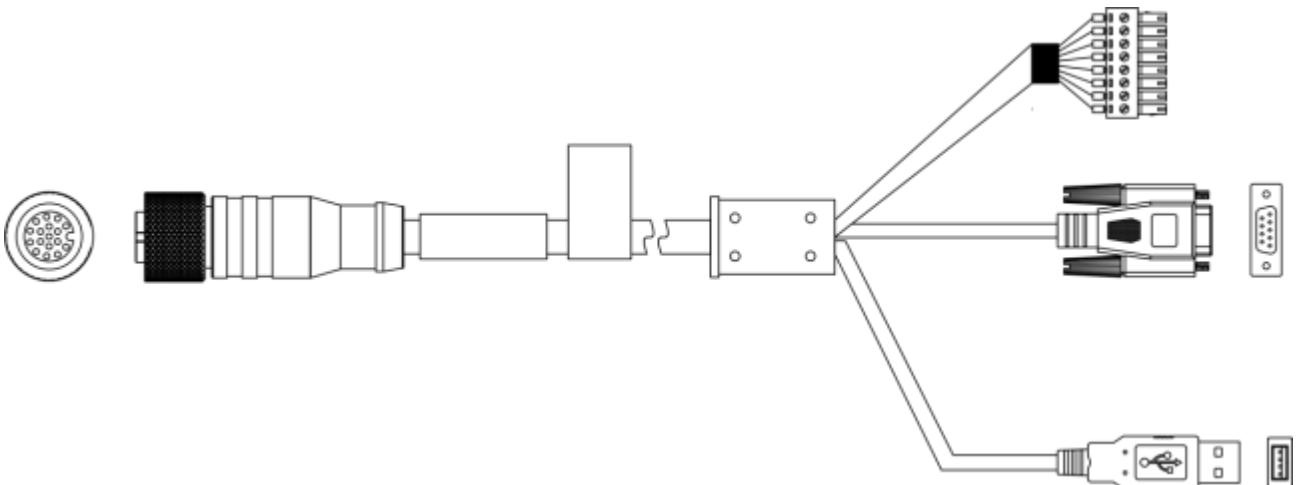

Figure 4-9 17-Pin Cable for Type I to Type V Devices

Refer to the figure and table below for the pin definitions of the 8-pin terminal.

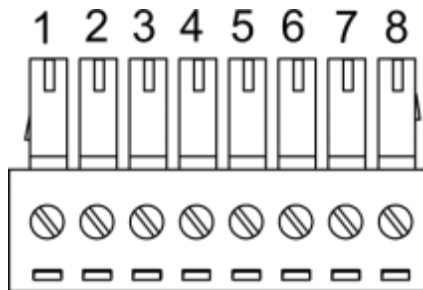

Figure 4-10 8-Pin Terminal

Table 4-8 8-Pin Terminal Definitions (Type I to Type V Devices)

| No. | Signal | Description | Cable Color |
|-----|----------|---|-------------|
| 1 | DO_5 | -- | Brown |
| 2 | DO_4 | -- | Blue |
| 3 | DO_3 | Non-isolated Output | Brown/White |
| 4 | DI_2 | Non-isolated Input | Blue/White |
| 5 | DI_1 | It can be configured as input or output, and is input by default. | White |
| 6 | DI_0 | It can be configured as input or output, and is input by default. | Gray |
| 7 | GND | Direct Current Power Supply Negative | Black |
| 8 | POWER_IN | Direct Current Power Supply Positive | Red |

Note

The supplied 17-pin cable may differ by device models.

Type VI Device

Type VI device has a DB15 connector. Refer to the figure and table below for connector pin definitions.

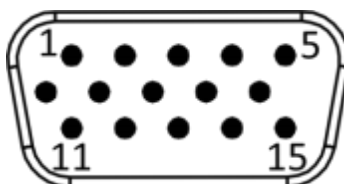

Figure 4-11 DB15 Connector

Table 4-9 Pin Definitions (Type VI Device)

| No. | Signal | I/O Signal Source | Description |
|-----|------------|-------------------|--------------------------------------|
| 4 | GND | -- | Direct Current Power Supply Negative |
| 9 | POWER_5V/N | -- | USB Power Interface |
| 11 | USB_DM | -- | USB2.0 Signal Negative |
| 12 | USB_DP | -- | USB2.0 Signal Positive |

For type VI device, you should use the supplied cable, as shown below, to wire the device. The cable has a 15-pin connector for connecting with the device, and a USB interface for connecting with the PC.



Figure 4-12 Cable for Type VI Device

Type VII Device

Type VII device with USB interface has a cable with 10-pin RJ45 female connector. It is recommended to use the supplied cable, as shown below, in the package when using the device. The supplied cable has a RJ45 male connector for connecting the device, and a USB interface for connecting external devices.



Figure 4-13 Cable for Type VII Device with USB Interface

The supplied cable also has four open lines with different colors, and you can wire them according to actual demands.

Table 4-10 Open Line Definitions

| No. | Signal | I/O Signal Source | Description | Color |
|-----|-----------|-------------------|---|--------|
| 1 | OPTO_OUT0 | LineOut 3 | Non-isolated Output | Brown |
| 2 | OPTO_IN0 | LineIn 1 | Non-isolated Input | Yellow |
| 3 | GPIO1 | Line 2 | It can be configured as input or output via the client software | Orange |
| 4 | GND | -- | Direct Current Power Supply Ground | Black |

4.3 Device with RS-232 Interface

Type VII device with RS-232 interface has a cable with 10-pin RJ45 female connector. It is recommended to use the supplied cable, as shown below, in the package when using the device. The supplied cable has a RJ45 male connector for connecting the device, and a DB9 interface for connecting external devices.



Figure 4-14 Cable for Type VII Device with RS-232 Interface

The supplied cable also has five open lines with different colors, and you can wire them according to actual demands.

Table 4-11 Open Line Definitions

| No. | Signal | I/O Signal Source | Description | Color |
|-----|-----------|-------------------|---|--------|
| 1 | OPTO_OUT0 | LineOut 3 | Non-isolated Output | Brown |
| 2 | OPTO_IN0 | LineIn 1 | Non-isolated Input | Orange |
| 3 | GPIO1 | Line 2 | It can be configured as input or output via the client software | Yellow |
| 4 | VCC | -- | Direct Current Power Supply Positive | Red |
| 5 | GND | -- | Direct Current Power Supply Ground | Black |

⚠ Caution

You cannot use DB9 serial port and VCC to power the device at the same time. Otherwise, damaging to power supply may occur.

4.4 IO Box

You can use IO box to connect NPN/PNP devices to access to pull-up and pull-down resistors.

- ID2000 series industrial code reader: You should use the supplied cable to connect the code reader to the top terminal of the IO box.
- External devices: You should connect external devices to the bottom terminal of the IO box.
- Pull-up and pull-down resistors: if the DIP switch is switched to **DOWN**, pull-down resistor

is connected. If the DIP switch is switched to **UP**, pull-up resistor is connected.

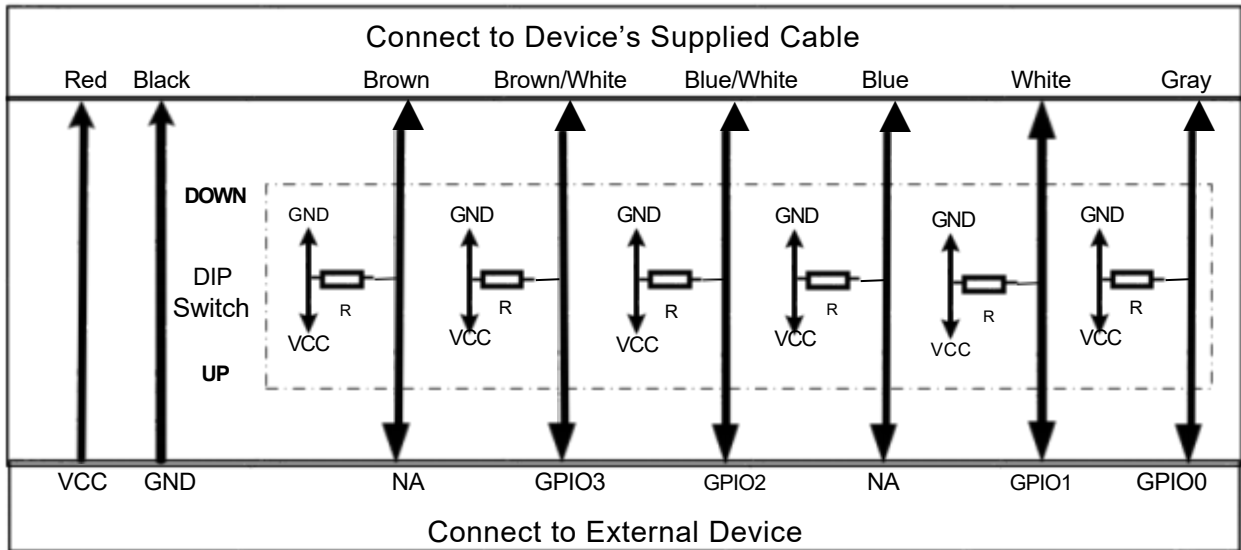

Figure 4-15 IO Box

Note

The IO box may not be included in the package due to different device models.

Chapter 5 Installation

5.1 Installation Preparation

You need to prepare following accessories before installation.

Table 5-1 Accessories

| No. | Name | Quantity | Description |
|-----|--------------------------------------|----------|--|
| 1 | Cable | 1 | It refers to the supplied cable that is included in the package. Refer to section Connector and Cable for details. |
| 2 | Power Adapter or Switch Power Supply | 1 | You should select suitable power adapter or switch power supply according to the device power supply and consumption. You need to purchase separately. |
| 3 | Screw Package | Several | It refers to the supplied screws that are used to fix the device to the installation position. |
| 4 | IO Box | 1 | It is used to connect NPN/PNP devices.  Note The IO box may not be included in the package due to different device models. |

5.2 Install Device

Before You Start

- Make sure that the device in the package is in good condition and all assembly parts are included.
- Make sure that all related equipment is powered off during the installation.

Caution

- Device with USB data interface may have a risk if it uses power supply of USB2.0 500 mA, and it is recommended to use USB3.0 power supply.
- Some models of the devices' supplied cable have power open line, which has the same function of DB9 connector to power the device. Do not use them at the same time. Otherwise, damaging to power supply may occur.
- When using industrial switching power supply for power supply, pay attention to the following matters:

- Before executing any installation or maintenance work, ensure that the power supply is separated from the main electric supply, and that it will not be suddenly or wiring problems connected to the main electric supply again.
 - Do not install the power supply in a humid environment, near liquids, high temperature environment, and direct sunlight or near fire sources.
 - The industrial switching power supply has exposed high-voltage terminals, please install it in a closed chassis or cabinet to prevent accidental contact with personnel.
 - The internal components of the power supply should maintain sufficient insulation distance between the mounting screws.
 - The fan and the cooling hole position cannot have any shelter. If the adjacent equipment belongs to the heat source, it must keep a distance of at least 10 cm to 15 cm from the equipment.
 - Please ensure that the power supply is grounded as required before use.
 - When using the power supply, do not exceed the upper limit of its output current and power. Refer to the power supply nameplate parameters for details.
 - Non-standard installation or use of the power supply in a high temperature environment will increase the temperature of internal components, resulting in a decrease in output power.
 - The power supply contains a high-voltage dangerous circuit. If there is any abnormality, please be sure to cutoff the power first and hand it over to a technician with electrical professional qualification. Please do not open the outer cover by yourself.
 - Do not touch the power terminal within 5 minutes after the power is cutoff. Otherwise, it may cause electric shock.
-

Steps

1. Use supplied screws to fix the device to the installation position.
 2. Use the supplied cable to wire the device according to pin definition mentioned in section **Connector and Cable**.
 - For type I to type V devices with fast Ethernet interface, connect the 17-pin M12 connector of the cable to the device, insert RJ45 connector of the cable into a switch or a PC for debugging images or transmitting data, and connect DB9 connector to a proper power adapter for power supply.
 - For type VI device with fast Ethernet interface, connect the DB15 connector of the cable to the device, insert RJ45 connector of the cable into a switch or a PC for debugging images or transmitting data, and connect DB9 connector to a proper power adapter for power supply.
 - For type I to type V devices with USB Interface, connect the 17-pin M12 connector of the cable to the device, and connect the USB interface of the cable to the PC.
 - For type VI device with USB interface, connect the device to the supplied cable via the DB15 connector, and connect the USB interface of the cable to the PC.
 - For type VII device with USB interface, insert RJ45 male connector of the cable into the device, and connect USB interface to external devices.
 - For type VII device with RS-232 interface, insert RJ45 male connector of the cable into the device, and connect RS-232 interface to external devices.
-

Chapter 6 I/O Electrical Feature and Wiring

6.1 I/O Electrical Feature and Wiring of Type V Device

6.1.1 Opto-isolated Input Circuit

Type V device's LineIn 0/1 are opto-isolated inputs, and internal circuit is as follows.

 **Note**

- The input voltage ranges from 5 VDC to 30 VDC.
- The breakdown voltage is 36 VDC. Keep voltage stable.

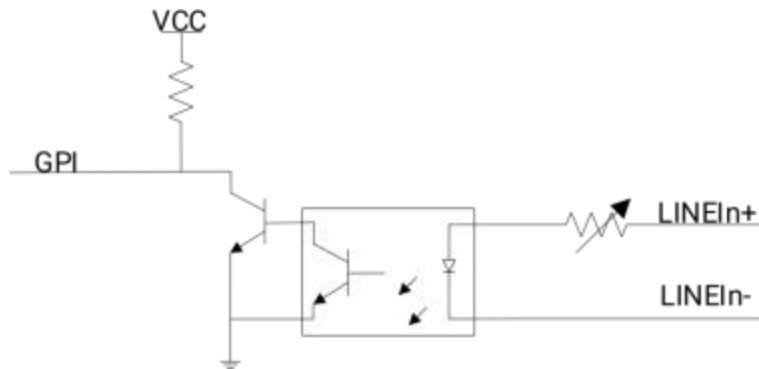

Figure 6-1 Internal Circuit of Input Signal

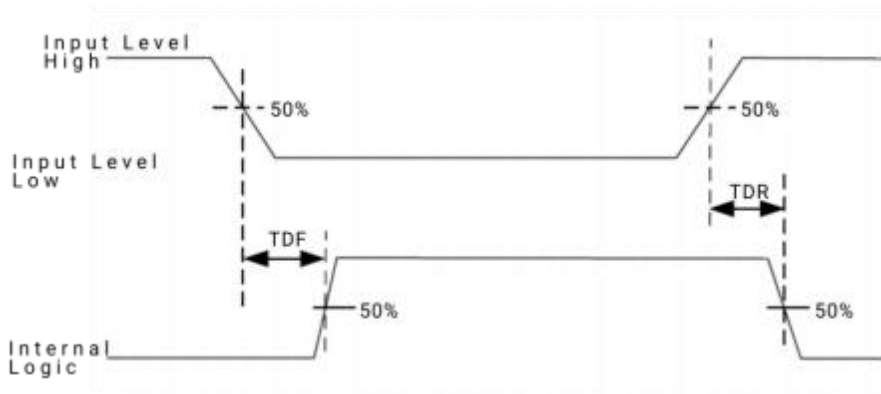

Figure 6-2 Input Logic Level

Table 6-1 Input Electrical Feature

| Parameter Name | Symbol | Value |
|------------------------|--------|--------------|
| Input Logic Level Low | VL | 1.5 VDC |
| Input Logic Level High | VH | 2 VDC |
| Input Falling Delay | TDF | 81.6 μ s |
| Input Rising Delay | TDR | 7 μ s |

6.1.2 Opto-isolated Output Circuit

Type V device's LineOut 0/1 are opto-isolated outputs, and internal circuit is as follows.

Note

- The output voltage ranges from 5 VDC to 30 VDC.
- The maximum output current is 25 mA.
- Do not directly connect with inductive load (e.g. DC motor, etc.) when outputting.
- If the external voltage and resistance change, the corresponding current of output signal and output logic level low may differ.

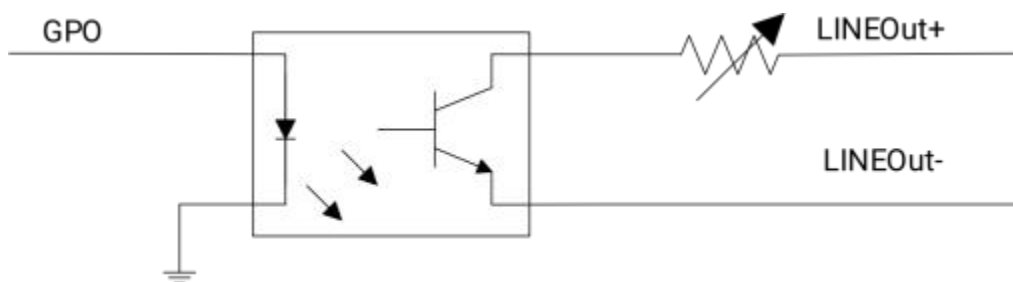

Figure 6-3 Internal Circuit of Output Signal

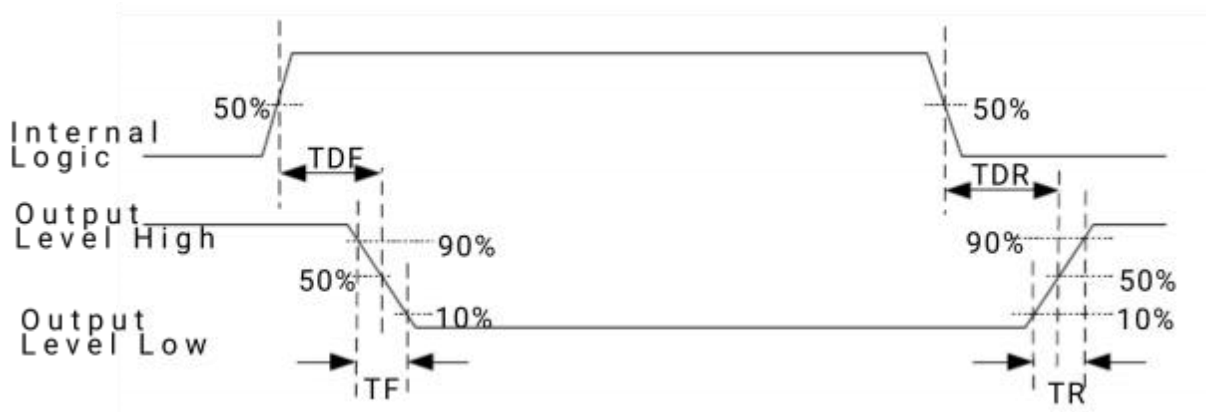

Figure 6-4 Output Logic Level

Table 6-2 Output Electrical Feature

| Parameter Name | Symbol | Value |
|-------------------------|--------|-------------|
| Output Logic Level Low | VL | 730 mV |
| Output Logic Level High | VH | 3.2 VDC |
| Output Falling Delay | TDF | 6.3 μ s |
| Output Rising Delay | TDR | 68 μ s |
| Output Falling Time | TF | 3 μ s |
| Output Rising Time | TR | 60 μ s |

6.1.3 Input Signal Wiring

The device can receive the external input signal, and this section introduces input signal wiring.

 **Note**

- Input signal wiring may differ by external device types.
- The voltage of VCC should be equal to or less than that of PWR. Otherwise, the output signal exception may occur.

PNP Device

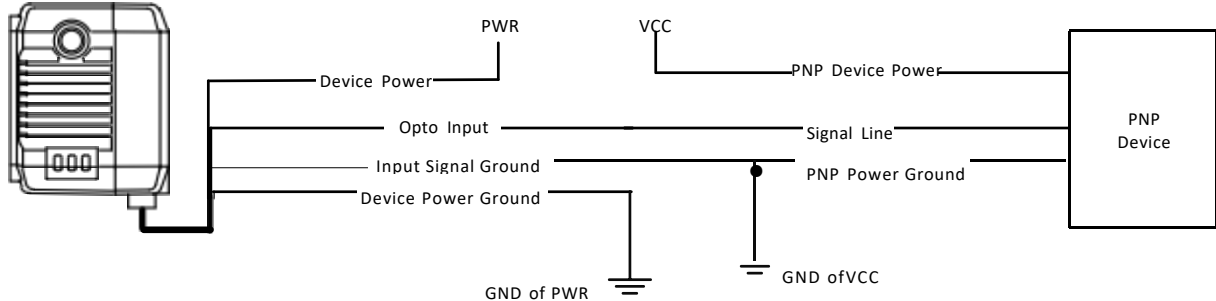

Figure 6-5 Input Signal Connecting to PNP Device

NPN Device

If the VCC of NPN device is 12 VDC or 24 VDC, and the pull-up resistor of the IO box is used.

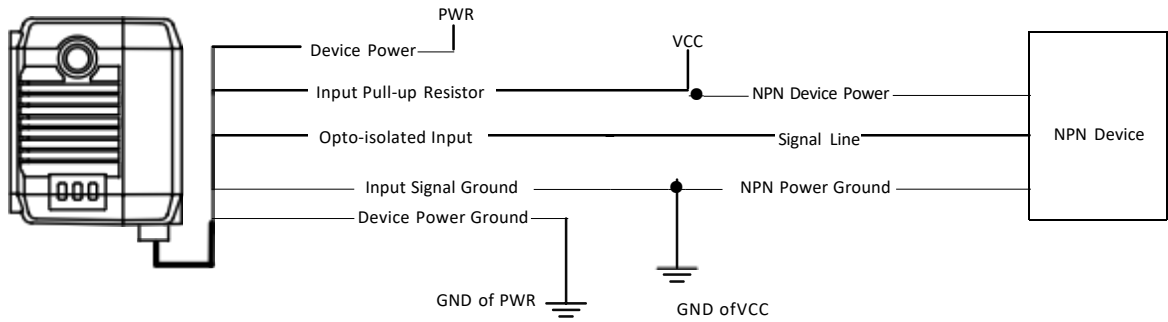

Figure 6-6 Input Signal Connecting to NPN Device (Pull-Up Resistor of IO Box Used)

If the VCC of NPN device is 12 VDC or 24 VDC and the external pull-up resistor is used, it is recommended to use 1 K Ω pull-up resistor.

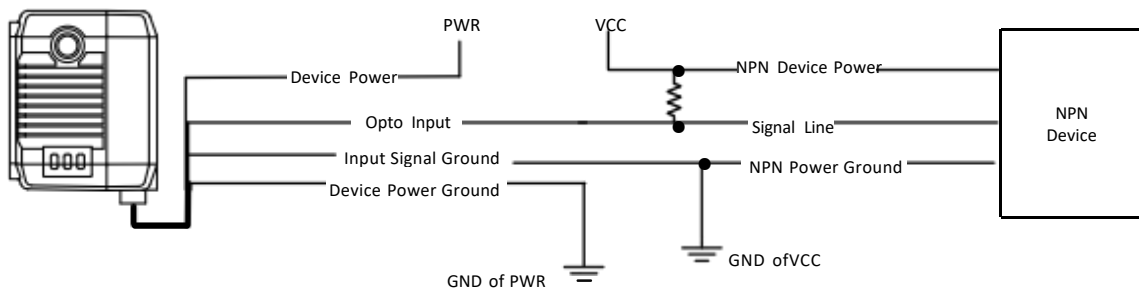

Figure 6-7 Input Signal Connecting to NPN Device (External Pull-Up Resistor Used)

6.1.4 Output Signal Wiring

Note

- Output signal wiring may differ by external device types.
- The voltage of VCC should be equal to or less than that of PWR. Otherwise, the output signal exception may occur.

PNP Device

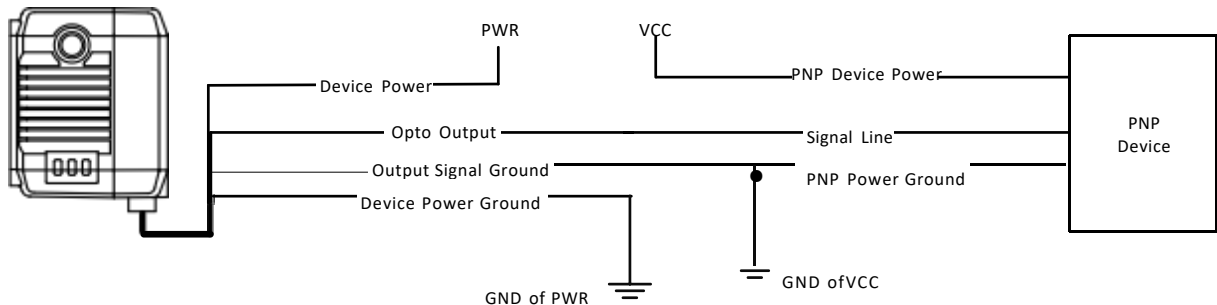

Figure 6-8 Output Signal Connecting to PNP Device

NPN Device

If the VCC of NPN device is 12 VDC or 24 VDC, and the pull-up resistor of the IO box is used.

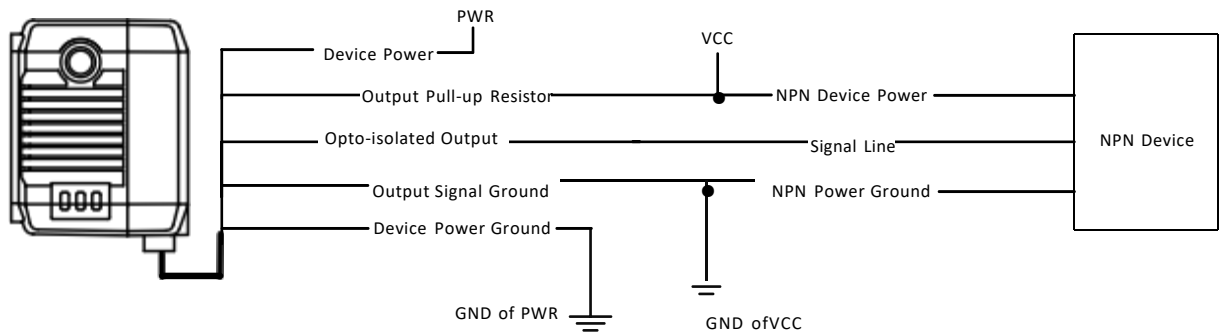

Figure 6-9 Output Signal Connecting to NPN Device (Pull-Up Resistor of IO Box Used)

If the VCC of NPN device is 12 VDC or 24 VDC and the external pull-up resistor is used, it is recommended to use 1 K Ω pull-up resistor.

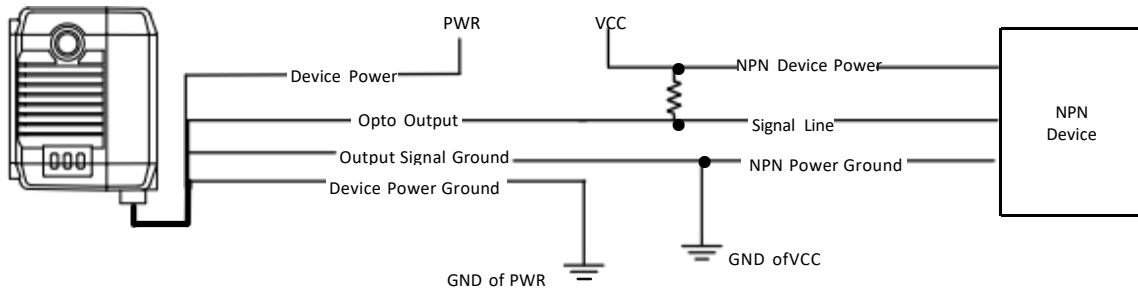

Figure 6-10 Output Signal Connecting to NPN Device (External Pull-Up Resistor Used)

6.2 I/O Electrical Feature and Wiring of Other Devices

The other devices include type I to type IV devices, and type VI and type VII devices. With different device types, their I/O electrical feature varies.

- Type II device: Its Line 0/1/2/3 are all bi-directional signals.
- Type I, type III, type IV and type VI devices: Their Line 2 is non-isolated input signal, Line 3 is non-isolated output signal, and Line 0/1 are both bi-directional signals.
- Type VII device: Its LineIn 1 is non-isolated input signal, LineOut 3 is non-isolated output signal, and Line 2 is bi-directional signal.

6.2.1 Non-isolated Input Circuit

The internal circuit of other devices' non-isolated input signal is as follows.



Figure 6-11 Internal Circuit of Input Signal

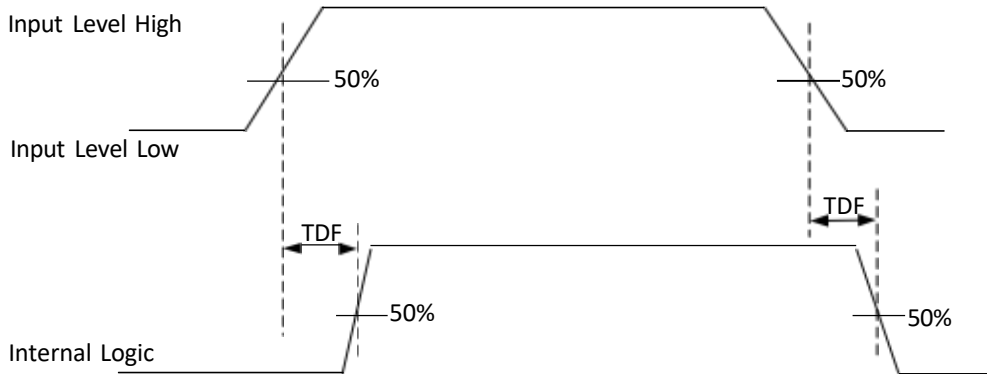

Figure 6-12 Input Logic Level

Table 6-3 Input Electrical Feature

| Parameter Name | Parameter Symbol | Value |
|------------------------|------------------|---|
| Input Logic Level Low | VL | <ul style="list-style-type: none"> • Type I, II, III and IV devices: 1 VDC • Type VI and VII devices: 0.6 VDC |
| Input Logic Level High | VH | 2 VDC |
| Input Falling Delay | TDF | 200 ns |
| Input Rising Delay | TDR | 1 μs |

6.2.2 Non-isolated Output Circuit

The internal circuit of the device’s non-isolated output signal is as follows.



Figure 6-13 Internal Circuit of Output Signal

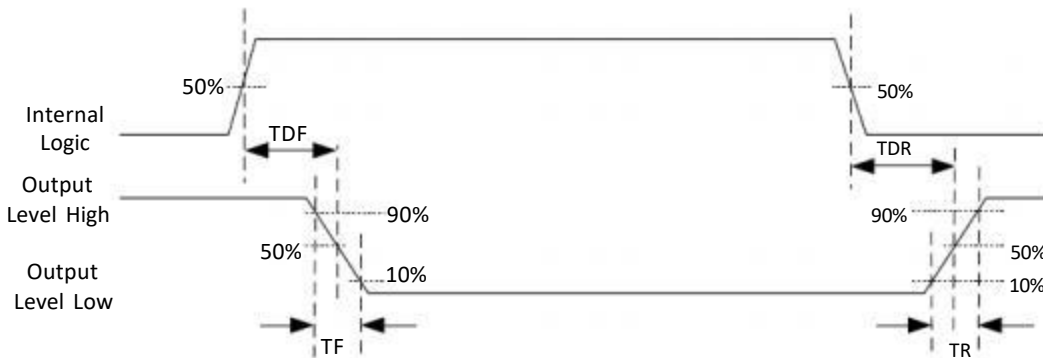

Figure 6-14 Output Logic Level

When the external voltage is 12 VDC and pull-up resistor is 1 KΩ, output electric feature is shown below.

Table 6-4 Output Electrical Feature

| Parameter Name | Parameter Symbol | Value |
|-------------------------|------------------|------------------------------------|
| Output Logic Level Low | VL | 500 mV |
| Output Logic Level High | VH | 12 VDC (external pull-up resistor) |
| Output Falling Delay | TDF | 330 ns |
| Output Rising Delay | TDR | 4.4 μs |
| Output Falling Time | TF | 116 ns |
| Output Rising Time | TR | 3.8 μs |

Relation between different external voltages and output logic level low is shown below.

Table 6-5 Parameters of Output Logic Level Low

| External Voltage | Output Logic Level Low (VL) |
|------------------|-----------------------------|
| 3.3 VDC | 180 mV |
| 5 VDC | 260 mV |

| External Voltage | Output Logic Level Low (VL) |
|------------------|-----------------------------|
| 12 VDC | 500 mV |
| 24 VDC | 900 mV |

6.2.3 Bi-directional I/O Circuit

The bi-directional signal in I/O signal can be use as input signal or output signal according to demands. Its internal circuit is shown below.

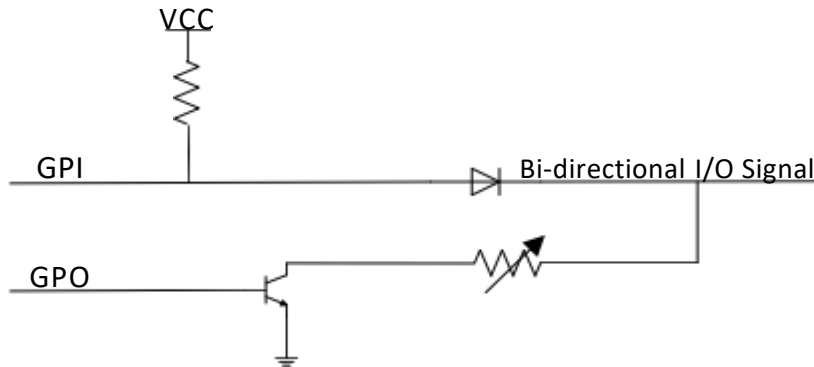

Figure 6-15 Internal Circuit of Bi-Directional Signal

Configured as Input Signal

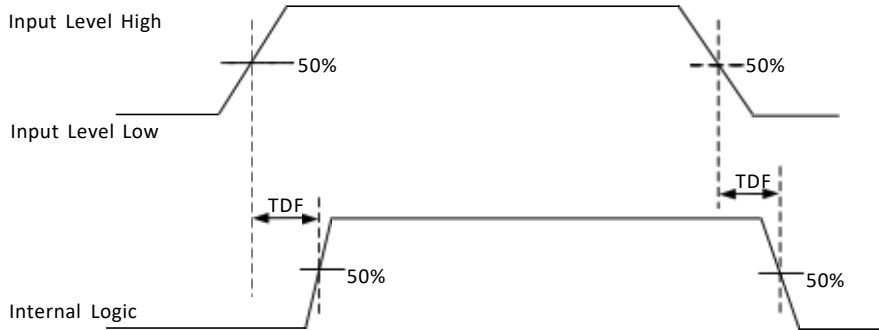

Figure 6-16 Input Logic Level

Table 6-6 Input Electrical Feature

| Parameter Name | Parameter Symbol | Value |
|------------------------|------------------|-----------|
| Input Logic Level Low | VL | 1 VDC |
| Input Logic Level High | VH | 2 VDC |
| Input Falling Delay | TDF | 200 ns |
| Input Rising Delay | TDR | 1 μ s |

Configured as Output Signal

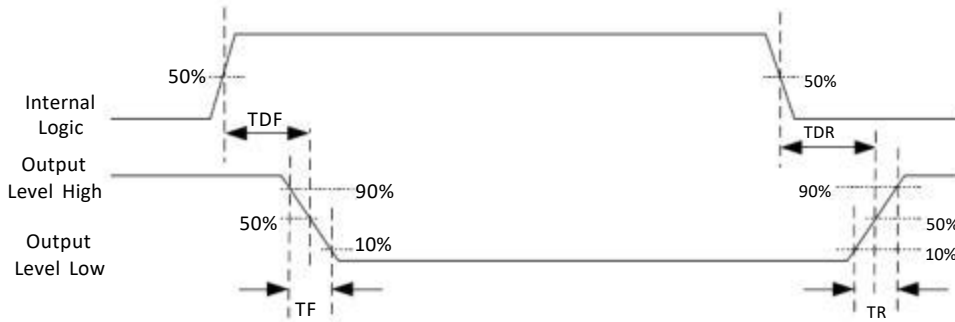

Figure 6-17 Output Logic Level

When the external voltage is 12 VDC and pull-up resistor is 1 K Ω , output electric feature is shown below.

Table 6-7 Output Electrical Feature

| Parameter Name | Parameter Symbol | Value |
|-------------------------|------------------|------------------------------------|
| Output Logic Level Low | VL | 500 mV |
| Output Logic Level High | VH | 12 VDC (external pull-up resistor) |
| Output Falling Delay | TDF | 330 ns |
| Output Rising Delay | TDR | 4.4 μ s |
| Output Falling Time | TF | 116 ns |
| Output Rising Time | TR | 3.8 μ s |

Relation between different external voltages and output logic level low is shown below.

Table 6-8 Parameters of Output Logic Level Low

| External Voltage | Output Logic Level Low (VL) |
|------------------|-----------------------------|
| 3.3 VDC | 180 mV |
| 5 VDC | 260 mV |
| 12 VDC | 500 mV |
| 24 VDC | 900 mV |

6.2.4 Input Signal Wiring

The device can receive the external input signal, and this section introduces input signal wiring.

Note

- Input signal wiring may differ by external device types.
- The voltage of VCC should be equal to or less than that of PWR. Otherwise, the output signal exception may occur.

PNP Device

Other devices apart from type VII device use the pull-down resistor of the IO box, the wiring is shown below.

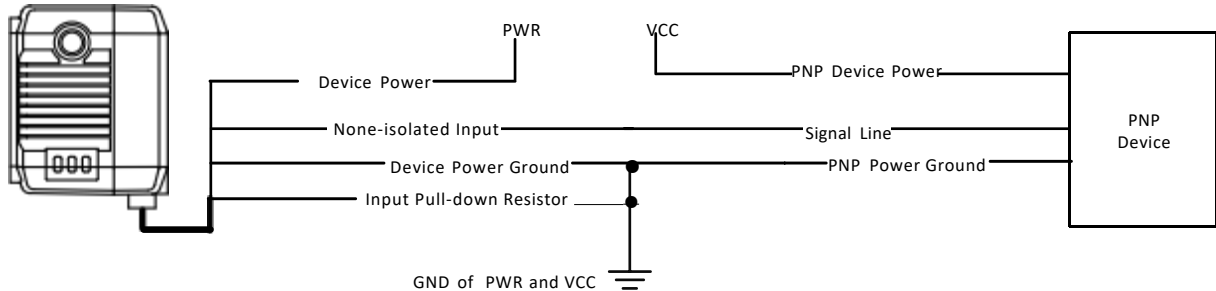

Figure 6-18 Input Signal Connecting to PNP Device (Pull-Down Resistor of IO Box Used)

Other devices apart from type VII device use external pull-down resistor, it is recommended to use 1 K Ω pull-down resistor.

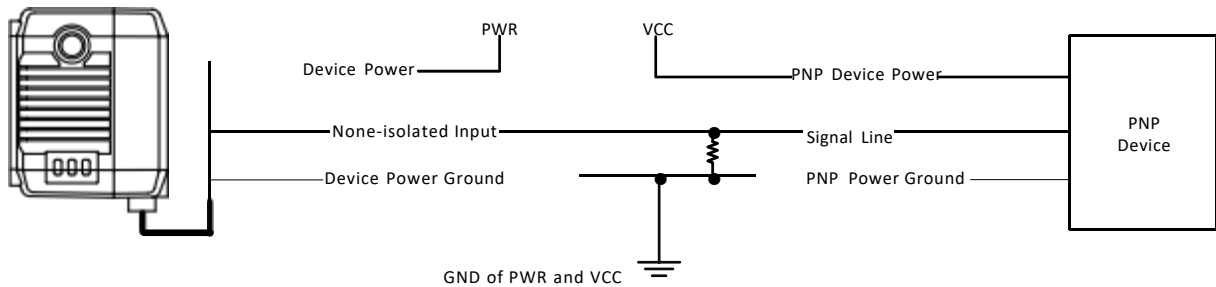

Figure 6-19 Input Signal Connecting to PNP Device (External Pull-Down Resistor Used)

Type VII device uses external pull-down resistor, it is recommended to use 1 K Ω pull-down resistor.

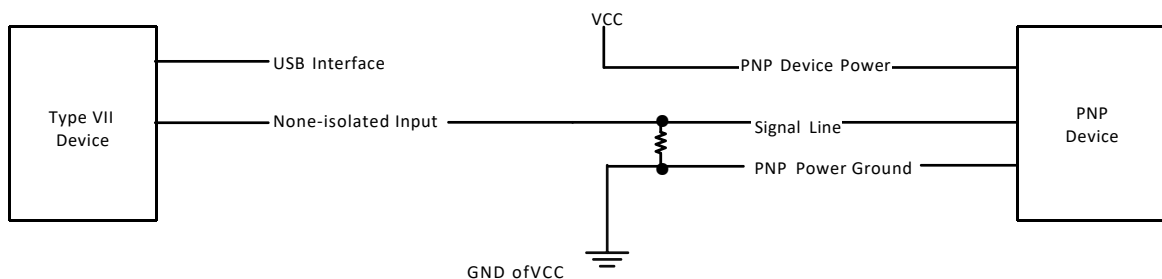

Figure 6-20 Input Signal Connecting to PNP Device (Type VII Device with USB Interface)

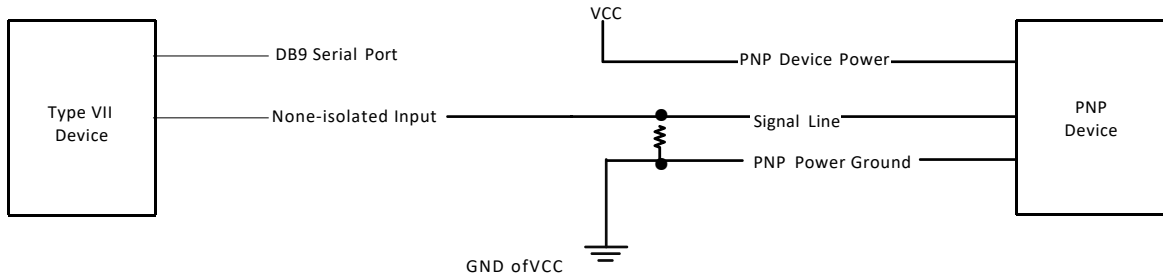

Figure 6-21 Input Signal Connecting to PNP Device (Type VII Device with RS-232)

NPN Device

Other devices apart from type VII device use the pull-up resistor of the IO box, the wiring is shown below.

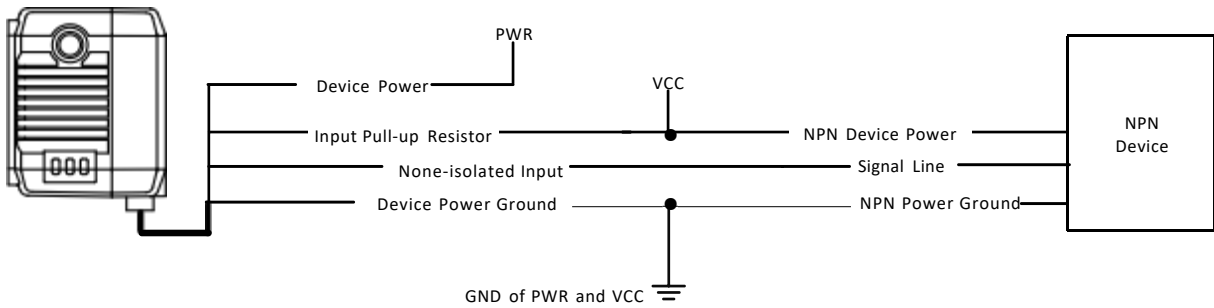

Figure 6-22 Input Signal Connecting to NPN Device (Pull-Up Resistor of IO Box Used)

Other devices apart from type VII device use external pull-up resistor, it is recommended to use 1 K Ω pull-up resistor.

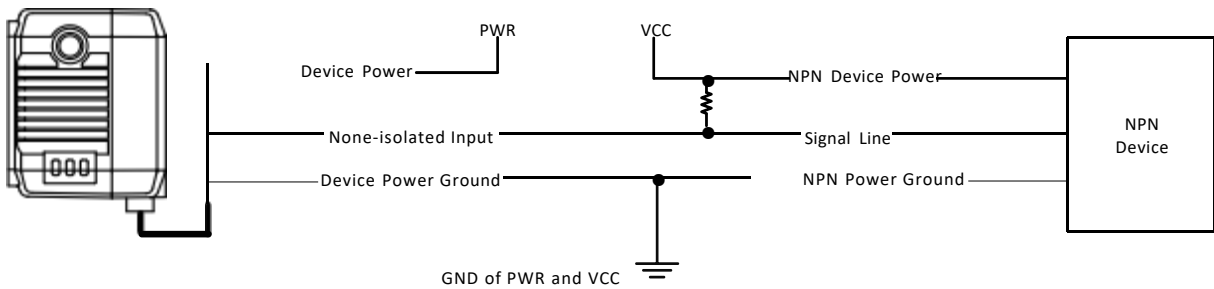

Figure 6-23 Input Signal Connecting to NPN Device (External Pull-Up Resistor Used)

Type VII device uses external pull-up resistor, it is recommended to use 1 K Ω pull-up resistor.

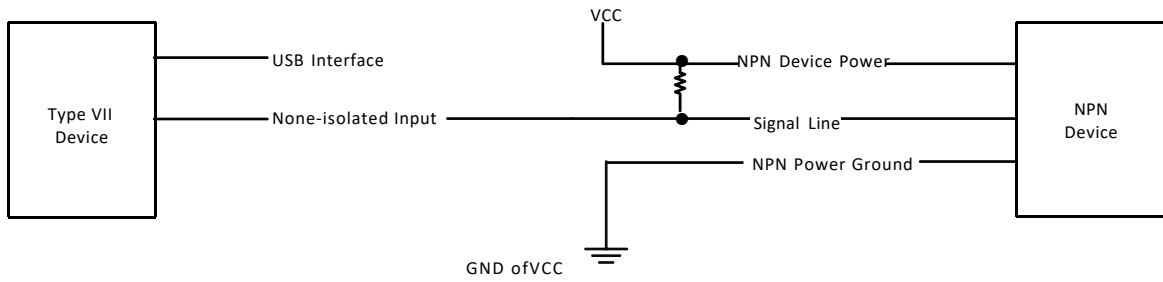

Figure 6-24 Input Signal Connecting to NPN Device (Type VII Device with USB Interface)

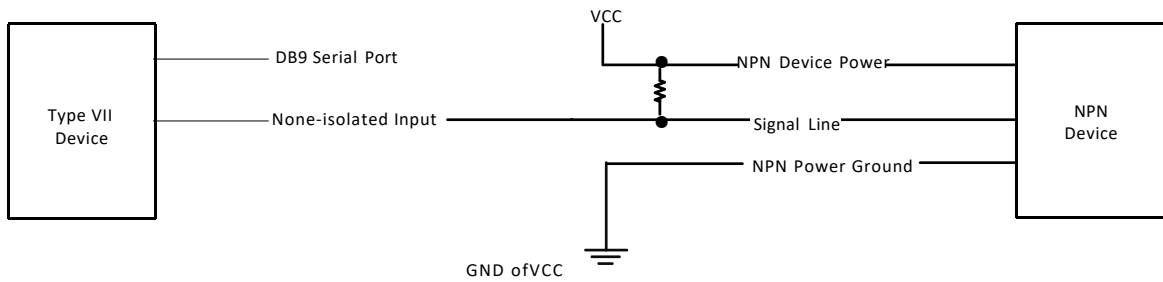

Figure 6-25 Input Signal Connecting to NPN Device (Type VII Device with RS-232) Switch

The switch can provide low electrical level to trigger the bi-directional I/O.

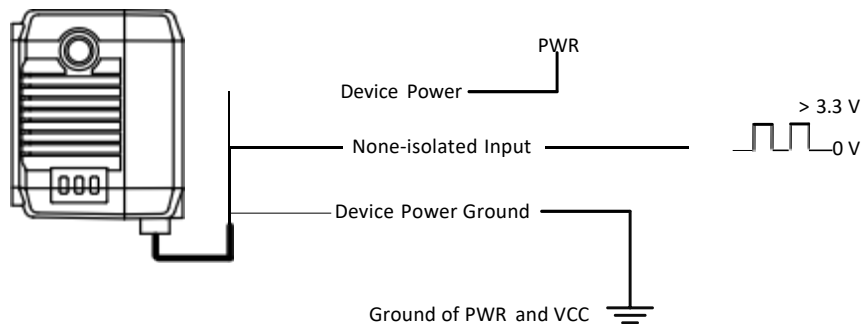

Figure 6-26 Input Signal Connecting to Switch (Other Devices Apart from Type VII Device)

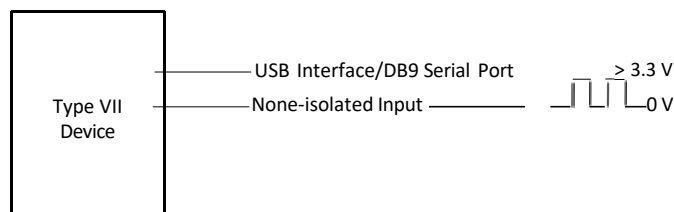

Figure 6-27 Input Signal Connecting to Switch (Type VII Device)

6.2.5 Output Signal Wiring

Note

- Output signal wiring may differ by external device types.
- The voltage of VCC should be equal to or less than that of PWR. Otherwise, the output signal exception may occur.

PNP Device

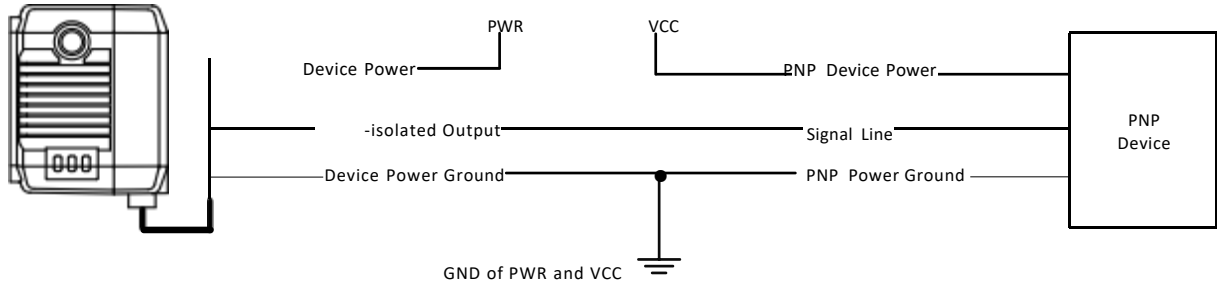

Figure 6-28 Output Signal Connecting to PNP Device (Other Devices Apart from Type VII)

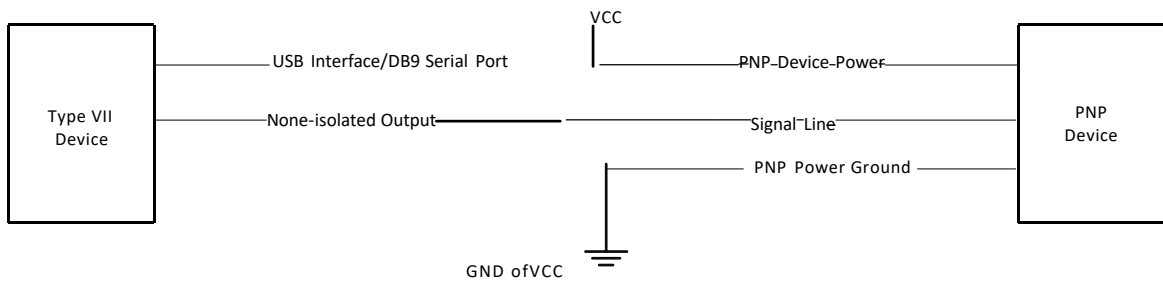

Figure 6-29 Output Signal Connecting to PNP Device (Type VII Device)

NPN Device

Other devices apart from type VII device use the pull-up resistor of the IO box, the wiring is shown below.

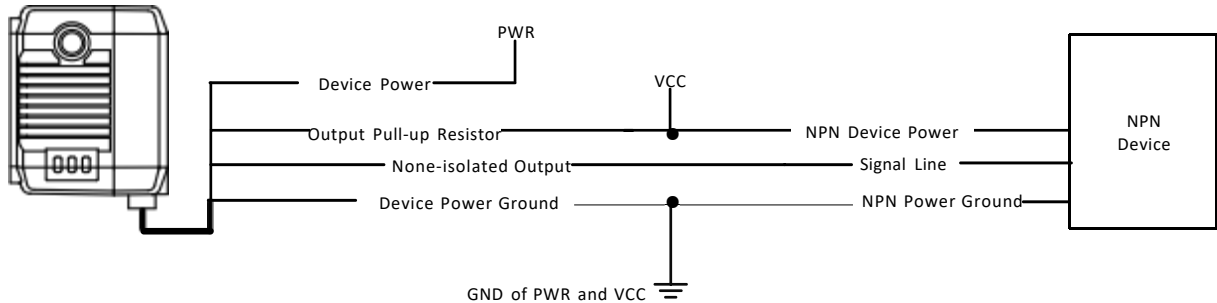

Figure 6-30 Output Signal Connecting to NPN Device (Pull-Up Resistor of IO Box Used)

Other devices apart from type VII device use external pull-up resistor, it is recommended to use 1 K Ω pull-up resistor.

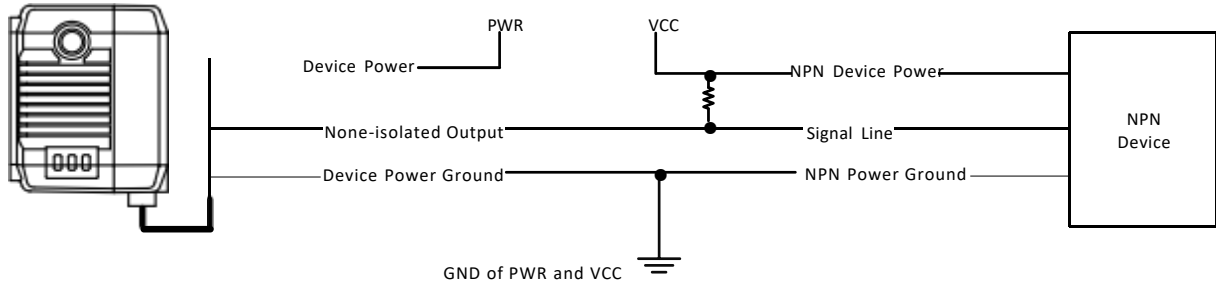

Figure 6-31 Output Signal Connecting to NPN Device (External Pull-Up Resistor Used)

Type VII device uses external pull-up resistor, it is recommended to use 1 K Ω pull-up resistor.

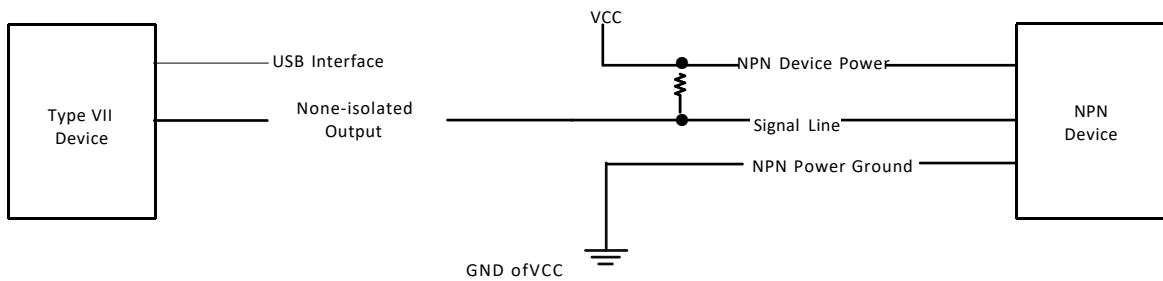

Figure 6-32 Output Signal Connecting to NPN Device (Type VII Device with USB Interface)

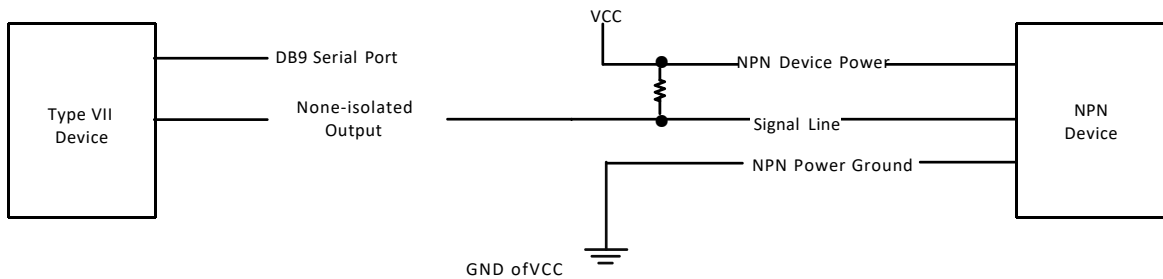

Figure 6-33 Output Signal Connecting to NPN Device (Type VII Device with RS-232)

6.3 RS-232 Serial Port

The device supports outputting data via RS-232 serial port, and the supplied cable has a 9-pin female serial port connector. Refer to the figure and table below for pin definitions.

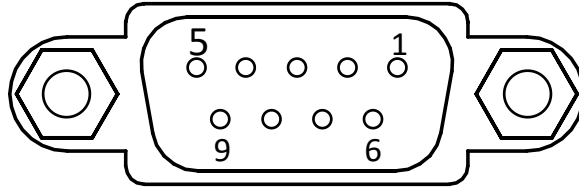

Figure 6-34 9-Pin Connector

Table 6-9 Pin Definitions (Other Devices Apart from Type VII)

| Pin No. | Name | Description |
|---------|------|----------------|
| 2 | TX | Transmits Data |
| 3 | RX | Receives Data |
| 5 | GND | Signal Ground |

Table 6-10 Pin Definitions (Type VII Device)

| Pin No. | Name | Description |
|---------|------|---------------------------------|
| 2 | TX | Transmits Data |
| 3 | RX | Receives Data |
| 4 | PWR | Power Supply (12 VDC To 24 VDC) |
| 5 | GND | Signal Ground |

⚠ Caution

In addition to the 4th pin, the serial port connector of the type VII device can also provides supply power to the device via its own DC input head, supporting 12 VDC to 24 VDC input. However, do not use the VCC pin of the OPEN line and the serial port connector to power the device at the sametime. Otherwise, damaging to power supply may occur.

Chapter 7 Device Connection

Device connection to the client software is required for device's configuration and remote operations. This section introduces how to install the client software, set PC and device network, connect the device to the client software, etc.

7.1 Install Client Software

IDMVS is a client software for device configuration and remote operations.

Steps

Note

- The client software is compatible with 32/64-bit Windows XP/7/10.
- It is recommended to use the latest version of the client software.
- The graphic user interface may differ by different versions of client software you use.

1. Double click the installation package to start installing the client software.
2. Select the language.
3. Read and check **Terms of the License Agreement**.
4. Click **Start Setup**.
5. Select installation directory and click **Next**.

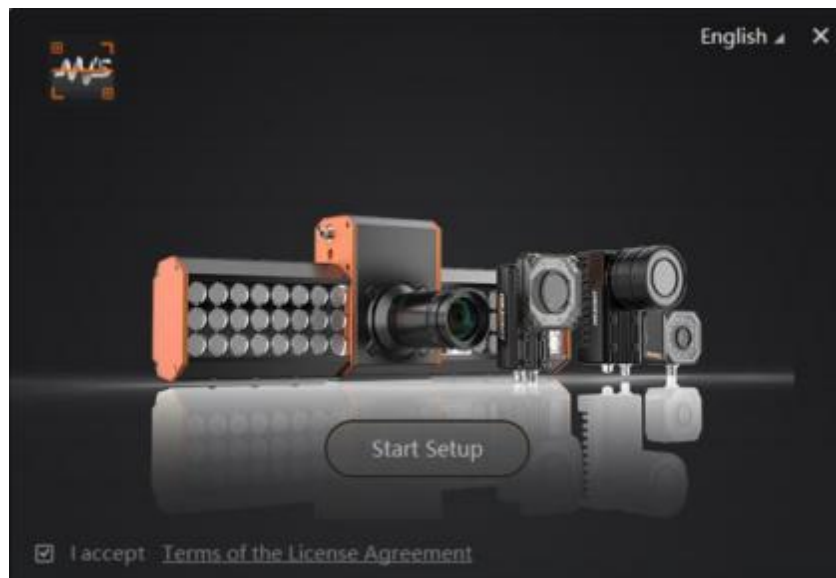

Figure 7-1 Installation Interface

6. Finish the installation according to the interface prompts.

7.2 Set PC Environment

To ensure stable client running and data transmission, you are recommended to set PC environment. For the device with fast Ethernet data interface, you need to turnoff the firewall and set PC network. For the device with USB data interface, you need to check the USB drive on the PC.

7.2.1 Turnoff Firewall for Network Device

Steps



For different Windows versions, the path name or interface may differ. Please refer to the actual condition.

1. Goto Windows Firewall.
 - Windows XP system: Click **Start** → **Control Panel** → **Security Center** → **Windows Firewall**.
 - Windows 7 system: Click **Start** → **Control Panel** → **Windows Firewall**.
 - Windows 10 system: Click **Start** → **Control Panel** → **System and Security** → **Windows Defender Firewall**.
2. Click **Turn Windows Defender Firewall on or off** on the left.
3. Select **Turnoff Windows Defender Firewall (not recommended)**.

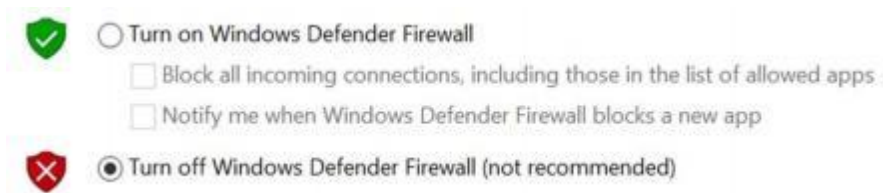

Figure 7-2 Windows Defender Firewall

4. Click **OK**.

7.2.2 Set PC Network for Network Device

To ensure stable data transmission and normal communication between the PC and the device via client software, you need to set the PC network and make sure that they are in the same network segment.

Steps

Note

For different Windows versions, the specific setting path and interface may differ. Please refer to the actual condition.

1. Goto PC network settings page: **Start** → **Control Panel** → **Network and Internet** → **Network and Sharing Center** → **Change adapter settings**.
2. Select NIC and set the IP obtainment mode.
 - Select **Obtain an IP address automatically** to get an IP address of the PC automatically.
 - Or select **Use the following IP address** to set an IP address for the PC manually.



Figure 7-3 Set PC Network

7.2.3 Check USB Drive for USB Device

Checking the USB drive on the PC is required before using the USB device. After connecting the USB device to the PC, the Windows system will automatically detect a new hardware device and install its corresponding drive.

Go to **Device Manager** by either pressing Win+X or right-clicking on the Windows menu button, and locate and expand the **Network adapters** to check the drive.

Note

- You can use the drive management tool to reinstall the USB drive if the installation is failed.
 - You can search the device with USB data interface in **GigE** of **Device Connection**.
 - Regarding type VI device, you need to execute “remote NDIS compatible device” operation when updating it firmware. Contact the technical support if necessary.
-

7.3 Set Device Network and Connect to Client Software

You can set and operate the device in the client software only when the device is in the same network segment with the PC where the client software is installed.

Steps



1. Double click the client software to run it.
2. Click  to find the device.
3. Right click the device to be connected, and click **Modify IP**.
4. Set the IP address of the device in the same network segment with the PC, and click **OK**.



Figure 7-4 Modify IP Address

5. Double click the device in device list or click  to connect it to the client software.
6. (Optional) Goto **Device Control** and enable **Preventing Illegal Occupation** to prevent IP address being occupied by other devices.
7. (Optional) Goto **Device Control** and enable **Force IP Enable** if you want to edit static IP address.

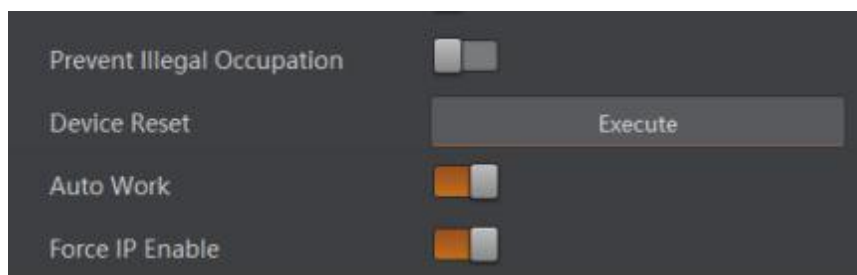

Figure 7-5 Preventing Illegal Occupation and Force IP Enable

Chapter 8 Basic Operation

8.1 Client Software Layout

The main window of the client software is displayed after the device is connected to the client software.

Note

- The graphic user interface may differ by different versions of client software you use.
- Refer to the user manual of the client software for detailed operation guide.

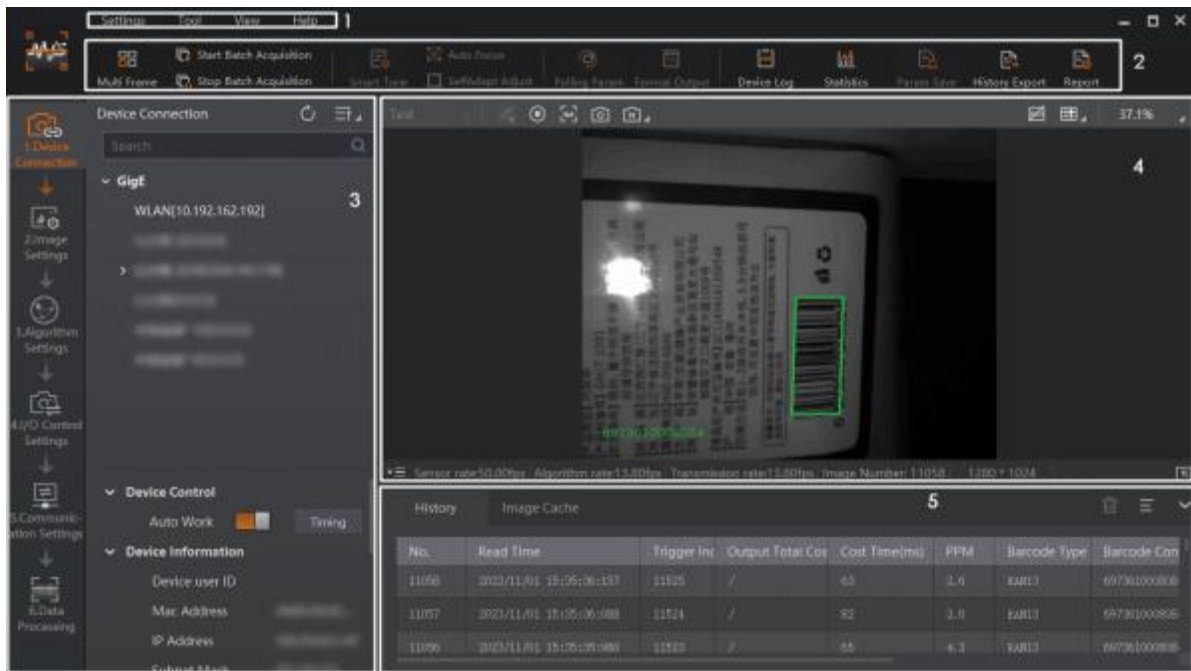

Figure 8-1 Main Window

Table 8-1 Main Window Description

| No. | Name | Description |
|-----|-----------------|---|
| 1 | Menu Bar | Provides access to function modules including Settings, Tool, View, and Help. |
| 2 | Control Toolbar | Provides access to functions such as starting/ending batch acquisition, switching the window division mode, viewing real-time statistics during acquisition, and viewing device logs, and quick access to tools such as Smart Tune, Auto Focus, and SelfAdapt Adjust. |

| No. | Name | Description |
|-----|-----------------------------------|---|
| 3 | Device Configuration Wizard Panel | The wizard for device configurations. In the Device Information field, you can view information about a device and its corresponding network interface. You can connect device(s) to the Software, manage devices by groups, and configure parameters related to image settings, algorithm settings, I/O control settings, communication settings, data processing, and configuration management. |
| 4 | Live View Window | Displays the live video of the selected device(s). |
| 5 | History Panel | Displays the code reading history of device(s). You can also view the real-time reading results during acquisition. |

The device configuration wizard panel and control toolbar help you perform some basic operations of the device.

Table 8-2 Device Configuration Wizard Panel Description

| No. | Module Name | Description |
|-----|--------------------------|--|
| 1 | Device Connection | You can connector disconnect device, modify device IP address, view device information, etc. |
| 2 | Image Settings | You can set image parameters, light parameters, etc. |
| 3 | Algorithm Settings | You can add different code type, set code number, etc. |
| 4 | I/O Control Settings | You can set parameters related with input and output. |
| 5 | Communication Settings | You can select different communication protocols, and set parameters for output result. |
| 6 | Data Processing | You can set filter rule for output result. |
| 7 | Configuration Management | You can save and load user parameters, and restart the device. |

8.2 Basic Operation

Steps

1. Goto the left corner of live view window, and select the operation mode.

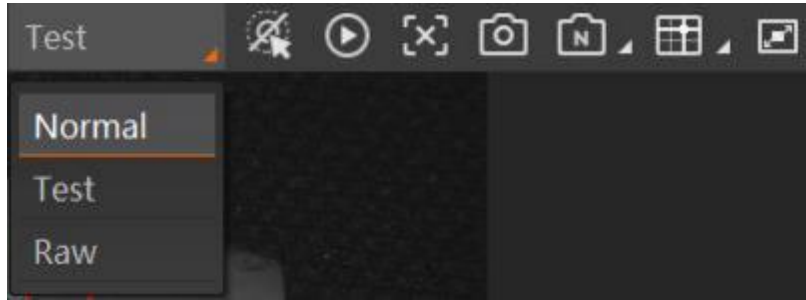

Figure 8-2 Select Operation Mode

Note

Stopping the real-time acquisition is required before selecting the operation mode.

Table 8-3 Operation Mode Description

| Device Mode | Description |
|-------------|--|
| Test Mode | It is used during device debugging. The device outputs images that are acquired in real-time, and displays code information. |
| Normal Mode | It is used during device normal operation. After reading code in image, the device outputs image and code information. |
| Raw Mode | It is used during testing image data. The device outputs raw data and displays code information. |

2. Click  in the live view window to view images and the code reading effect.

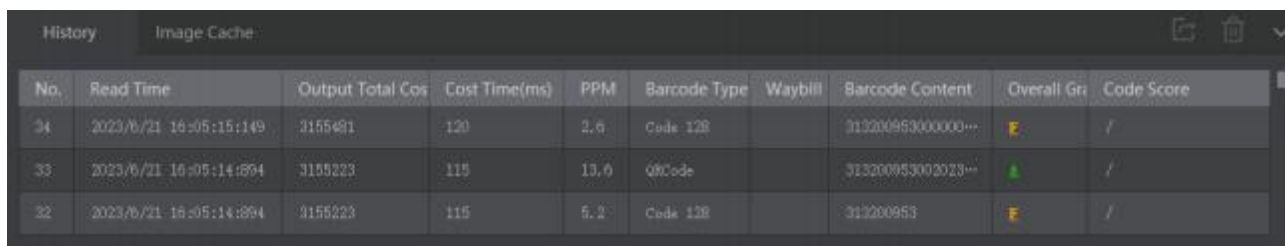

Figure 8-3 Code Reading Effect

Note

If the effect is not very good, you can adjust the focus knob (type II and type III devices only) or via autofocus function (type I device only) or related parameters like exposure time, gain, etc. in the **Image Settings** area.

3. (Optional) Goto history panel to view codes recognized by the device.



The screenshot shows a software interface with a 'History' tab selected. Below the tab is a table with the following columns: No., Read Time, Output Total Cos, Cost Time(ms), PPM, Barcode Type, Waybill, Barcode Content, Overall Gri, and Code Score. The table contains three rows of data.

| No. | Read Time | Output Total Cos | Cost Time(ms) | PPM | Barcode Type | Waybill | Barcode Content | Overall Gri | Code Score |
|-----|------------------------|------------------|---------------|------|--------------|---------|--------------------|-------------|------------|
| 34 | 2023/6/21 16:05:15:149 | 3155491 | 120 | 2.6 | Code 128 | | 313200953000000... | F | / |
| 33 | 2023/6/21 16:05:14:894 | 3155223 | 115 | 13.6 | QRCode | | 313200953003023... | A | / |
| 32 | 2023/6/21 16:05:14:894 | 3155223 | 115 | 5.2 | Code 128 | | 313200953 | F | / |

Figure 8-4 History Record

Chapter 9 Device Settings

9.1 Feature Tree Introduction

After the device is connected to the client software, and you can right click the device in **Device Connection**, and click **Feature Tree**.

 **Note**

The parameters of the feature tree may differ by device models and firmware versions.

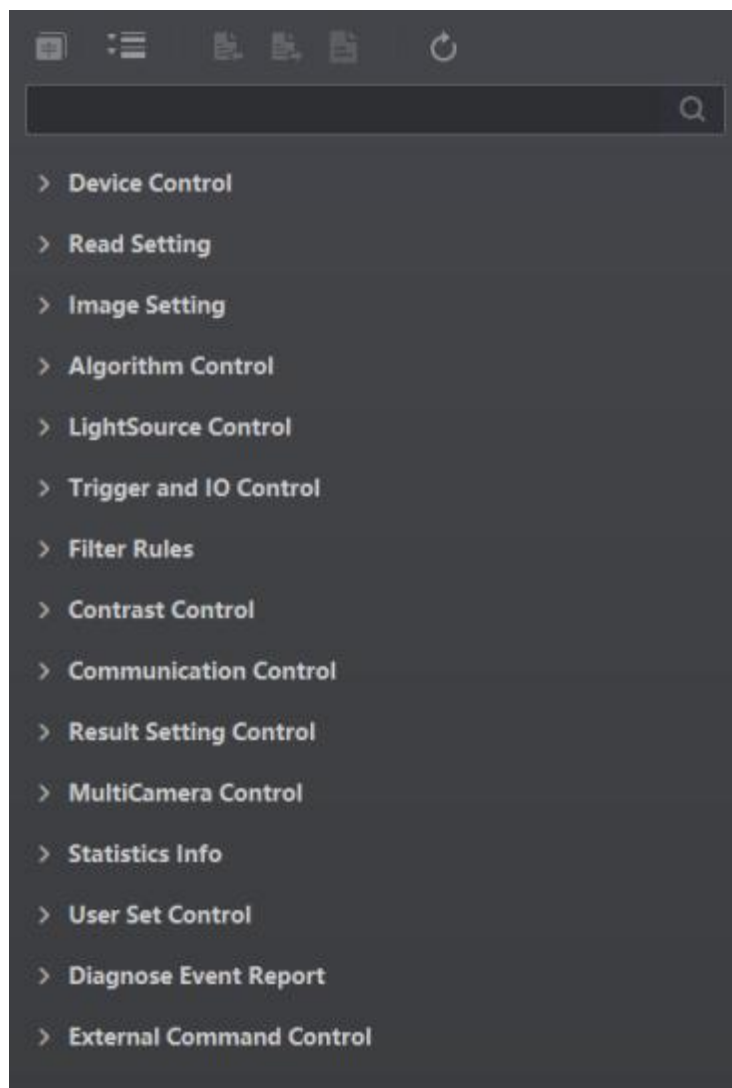

Figure 9-1 Feature Free

Table 9-1 Feature Tree Description

| Name | Description |
|------------------------|---|
| Device Control | It allows you to view the device's information, edit its name, etc. |
| Read Setting | It allows you to set the device's operation mode and select code types. |
| Image Setting | It allows you to set frame rate, exposure, gain, Gamma, etc. |
| Algorithm Control | It allows you to algorithm parameters. |
| Focus Control | It allows you to set the device's focus mode and related parameters. |
| Self Adapt Control | It allows the device to automatically adjust exposure, gain, Gamma and other parameters to have a better code reading effect. |
| Light Source Control | It allows you to set the light source's parameters. |
| Line Mode Control | It allow you to customize the specific line as input or output according to actual demands. |
| Trigger and IO Control | It allows you to set parameters of input and output. |
| Stop Trigger Control | It allows you to stop device trigger via TCP, UDP, I/O, serial port and USB. You can also set code reading timeout duration or max. code amount to be read to stop trigger. |
| Filter Rules | It allows you to set the filter rule of codes. |
| Communication Control | It allows you to set parameters related to different communication protocols. |
| Multi Camera Control | It allows you to set parameters of multi-camera to let them operate in a collaborative way. |
| Result Setting Control | It allows you to set parameters of outputted contents. |
| Statistics Info. | It allows you to count data related with code reading. |
| User Set Control | It allows you to save and load configured user set. |
| Diagnose Event Report | It allows you to monitor memory and CPU usage rate, and let you know when there is a crash, higher CPU usage rate, insufficient memory, etc. |

9.2 Code Reading Mode Settings

The device supports different code reading modes, including accurate mode and batch mode.

Steps

1. Right click the device in **Device Connection**, and click **Feature Tree**.
2. Go to **Trigger and IO Control** → **Accurate Mode Enable**, and enable **Accurate Mode Enable**.

 **Note**

Enabling **Accurate Mode Enable** is accurate mode, and disable it is batch mode.

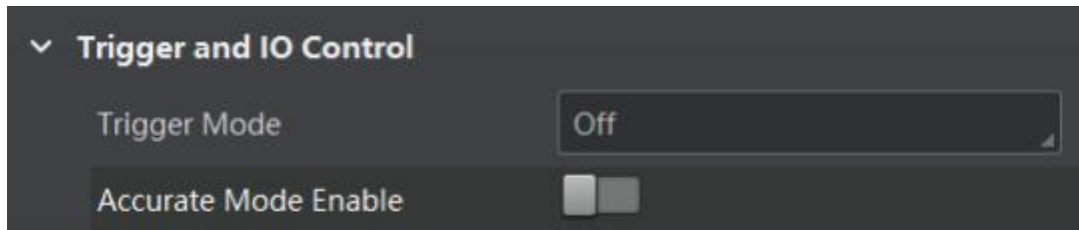

Figure 9-2 Code Reading Mode Settings

Table 9-2 Parameters Description

| Code Reading Mode | Description |
|-------------------|---|
| Accurate Mode | It reads codes containing the cross laser center in the code area only. The code reading process ends if codes are read successfully or the trigger switch is released. |
| Batch Mode | It can read multiple codes when the trigger switch is pressed. After code reading is finished, the result will be packaged and outputted. The code reading process ends if expected code quantity is reached or exceeded, code reading timed out, valid frame quantity is reached, or the trigger switch is released. |

 **Note**

The function of code reading mode may differ by device models.

9.3 Image Quality Settings

This section introduces how to set image related parameters of the device via client software.

 **Note**

For different models of the device, the specific parameters may differ, and the actual device you purchased shall prevail.

9.3.1 Set Image

You can set parameters like exposure time, gain, Gamma, acquisition frame rate, acquisition burst frame count, etc. in **Image Settings** area.

Table 9-3 Set Image Parameters

| Name | Description |
|-------------------------------|--|
| Exposure Time | You can increase exposure time to improve image brightness. Note To some extent, increasing exposure time will reduce acquisition frame rate, and impact image quality. |
| Gain | You can increase gain to improve image brightness. Note To some extent, increasing exposure time will reduce acquisition frame rate, and affect image quality. |
| Gamma | Gamma allows you to adjust the image contrast. It is recommended to reduce Gamma to increase brightness in dark background. |
| Acquisition Frame Rate | Acquisition frame rate refers to the image number that is acquired by the device per second. |
| Acquisition Burst Frame Count | Acquisition burst frame count refers to the outputted image number when the device is triggered once. |
| Polling Enable | It enables the polling function, you can select off, single or multiple mode. Note The parameter of polling enable will be displayed only when the trigger mode is on. |



Figure 9-3 Set Image Parameters

9.3.2 Set Polling

The polling function allows the device to acquire images based on the parameters you set, including exposure time, gain, Gamma, light source, focus position, etc. Currently, two types of polling modes are available, including single mode and multiple mode.

Note

- Stopping the real-time acquisition is required before setting the polling function.
- After the polling enabled, the device acquires images with its max. frame rate. Once the polling disabled, the frame rate you set in **Acquisition Frame Rate** takes effect.
- The polling function and specific parameters may differ by device models.
- It is recommended to use the polling function under the normal operation mode, and test/raw modes are used for debugging only.
- The specific parameters of polling may differ by device models.

Single Mode

Steps

1. Right click the device in **Device Connection**, and click **Feature Tree**.
2. Goto **Image Setting** → **Polling Mode**, and select **Single** as **Polling Enable**.
3. Select one parameter (e.g. **Param1**) from **Polling Param**.

Note

Up to 8 sets of parameter can be selected from **Polling Param**.

4. Set parameters participating the polling like **Polling Exposure Time**, **Polling Gain**, **Polling Gamma**, etc. according to actual demands.

Table 9-4 Parameters of Single Mode Polling

| Parameter | Description |
|---------------------------|---|
| Polling Exposure Time | It sets the exposure time of polling. |
| Polling Gain | It set the polling gain. |
| Polling Gamma | It sets the polling Gamma value. <ul style="list-style-type: none"> • If the value is between 0 and 1, when the image brightness increases, dark area becomes brighter. • If the value is between 1 and 4, when the image brightness decreases, dark area becomes darker. |
| Polling Focus Enable | After enabling this parameter, you can set polling focus position. |
| Polling Focus Position | It sets the polling focus position. |
| Polling Lighting Selector | It selects lamps on different directions, including up/down and mid. |

| Parameter | Description |
|-------------------------|---|
| Polling Lighting Enable | After enabling this parameter, the light source will turn on. |

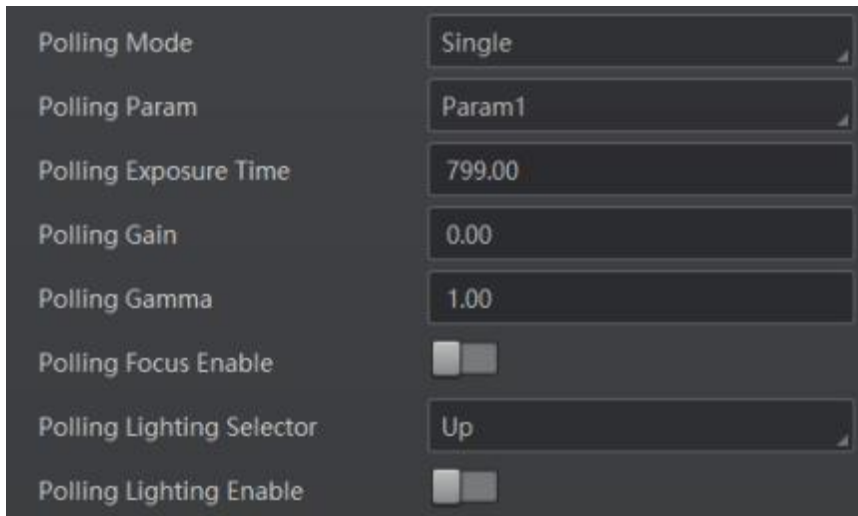

Figure 9-4 Single Mode

Multiple Mode

Note

- In multiple mode, the device supports trigger parameters like software trigger, external trigger, etc., does not support stopping polling via the external trigger.
- The rule for multiple-mode polling is that the polling is started from the polling parameter with Best Polling Group Idx, and then execute other polling parameters you selected in turn. For example, if the Param3 is the Best Polling Group Idx and Param1, Param2, Param4 and Param5 are enabled, the polling order is Param3 > Param1 > Param2 > Param4 > Param5.

Steps

1. Right click the device in **Device Connection**, and click **Feature Tree**.
2. Goto **Image Setting** → **Polling Mode**, and select **Multiple** as **Polling Enable**.
3. Set **Polling Time** and **Polling Period** according to actual demands.
 - **Polling Time** is used to determine whether the polling is finished or not, and it ranges from 100 to 2147482.
 - **Polling Period** is whole period from Param1 to Param8, and it ranges from 1 to 5000.
4. Select 2 to 8 sets of parameters (e.g. **Param1** and **Param2**) from **Polling Param**, and enable **Polling Param Enable** to let them take effect.
5. Set parameters participating the polling like **Polling Exposure Time**, **Polling Gain**, **Polling Gamma**, etc. according to actual demands.

Table 9-5 Parameters of Multiple Mode Polling

| Parameter | Description |
|---------------------------|---|
| Polling Exposure Time | It sets the exposure time of polling. |
| Polling Gain | It set the polling gain. |
| Polling Gamma | It sets the polling Gamma value. <ul style="list-style-type: none"> • If the value is between 0 and 1, when the image brightness increases, dark area becomes brighter. • If the value is between 1 and 4, when the image brightness decreases, dark area becomes darker. |
| Polling Focus Enable | After enabling this parameter, you can set polling focus position. |
| Polling Focus Position | It sets the polling focus position. |
| Polling Lighting Selector | It selects lamps on different directions, including up/down and mid. |
| Polling Lighting Enable | After enabling this parameter, the light source will turn on. |

6. Repeat step 4 and step 5 to set other parameters from **Polling Param**.

7. (Optional) View **Polling Status** and **Best Polling Group Idx**.

- **Polling Status:** It displays the current polling status. 0 stands for polling ended, and 1 stands for polling started.
- **Best Polling Group Idx:** It is used to display the polling parameter number when the device recognizes codes after enabling polling. If the polling is disabled or polling parameters are edited, it displays 1 by default.



Figure 9-5 Multiple Mode

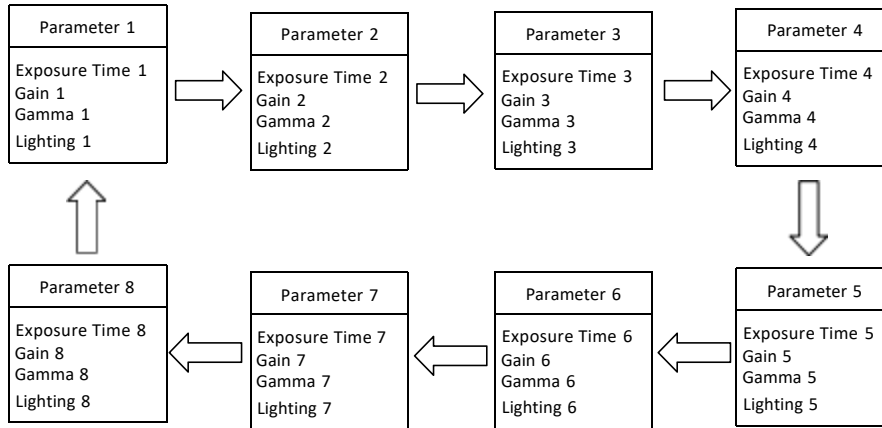

Figure 9-6 Polling Diagram

9.3.3 Set Light Source

Light source control allows you to enable the device’s aiming system and light source, and set related parameters according to actual demands.

Note

- Light source parameters may differ by device models.
- Make sure you have selected the device to be set in **Device Connection** before setting light source parameters.

Type I Device to Type VI Device

Steps

1. Go to **Image Settings** → **Light**, and enable **Aiming Light Enable** according to actual demands.
2. Enable **Lighting Enable** to enable the light source according to actual demands.
3. (Optional) Set **Lighting Duration** and **Precharge Time** if **Lighting Enable** is enabled.

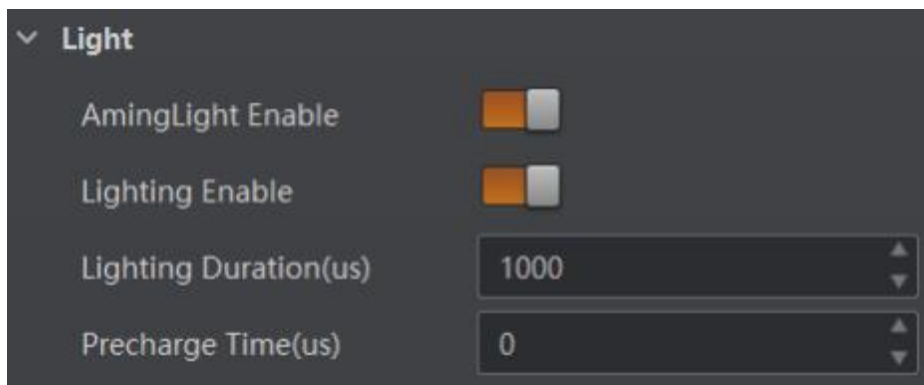

Figure 9-7 Set Light Source (Type I Device to Type VI Device)

Type VII Device

Steps

1. Goto **Image Settings** → **Light**, and select **Lighting Mode** according to actual demands.
2. Enable **Laser Enable** according to actual demands.
3. Enable **Laser Delay Enable**, and enter **Laser Delay Duration** to delay the close time of the laser after the device stops triggering.

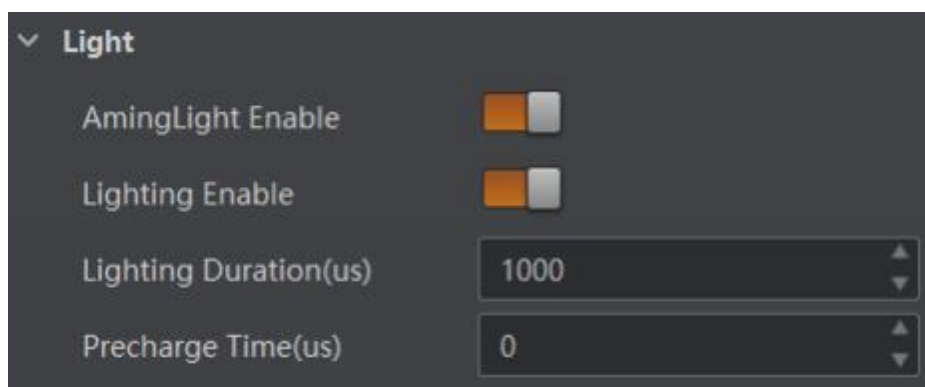

Figure 9-8 Set Light Source (Type VII Device)

9.3.4 Set Smart Tune

The smart tune function allows you to adjust the device's focus position, exposure, gain, etc. by one-key operation, and supports self-adaptive adjustment.

The smart tune function has two methods to be realized, including smart tune by pressing tune button and smart tune via the client software.

Smart Tune by Pressing Tune Button

Note

- The parameters of the smart tune may differ by device models and firmware versions.
- During the process of smart tune, the focus parameters and self-adaptive parameters will be adjusted in turn.

Steps

1. Goto **Image Settings**, click **All Features** on the right corner, and find **Smart Tune Control**.
2. Enable **Button Tune**, and disconnect the device from the client software.

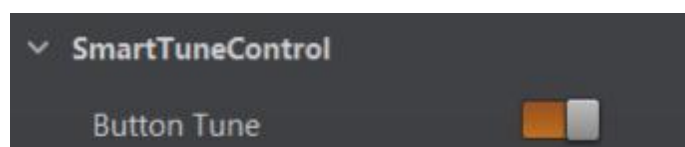

Figure 9-9 Button Tune

 **Note**

Smart tune by pressing the tune button is not supported if the device is connected via the client software.

3. Hold the tune button for 3 sec and the device starts smart tune.
 - During smart tune process, the status indicator flashes in green and red colors alternatively.
 - If smart tune succeeds, the status indicator is solid green lasting 3 sec and then restores.
 - If smart tune fails, the status indicator is solid red lasting 3 sec and then restores.
4. (Optional) Hold the button for 3 sec again during smart tune process, and the smart tune will be cancelled.

Smart Tune via Client Software

Apart from pressing tune button to realize smart tune, you can also configure parameters via the client software to realize it.

Before You Start: Make sure that the device is not in trigger mode, and its operation mode is test.

Steps

1. Goto **Image Settings**, click **All Features** on the right corner, and find **Smart Tune Control**.

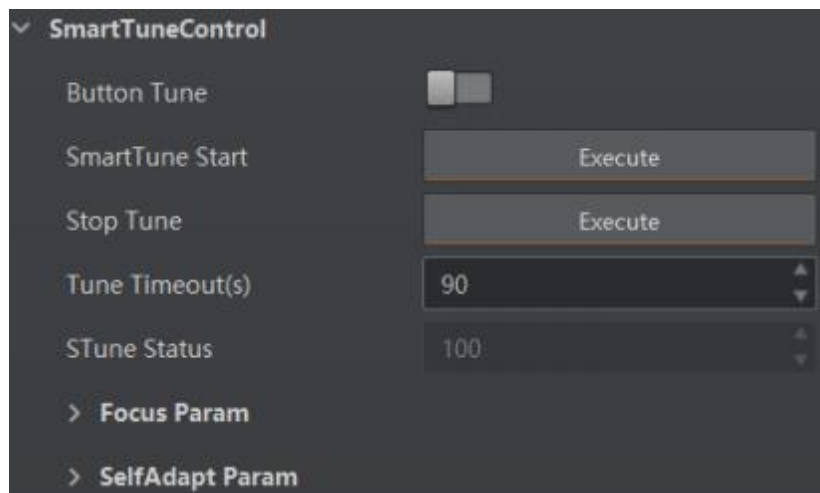

Figure 9-10 Smart Tune Control

2. (Optional) Set **Tune Timeout**. If the self-adaptive adjustment exceeds configured value, and it will stop automatically.
3. Click **Execute** in **Smart Tune Start** to let the device start smart tune, and a window of smart tune will be displayed for you to view the effect.

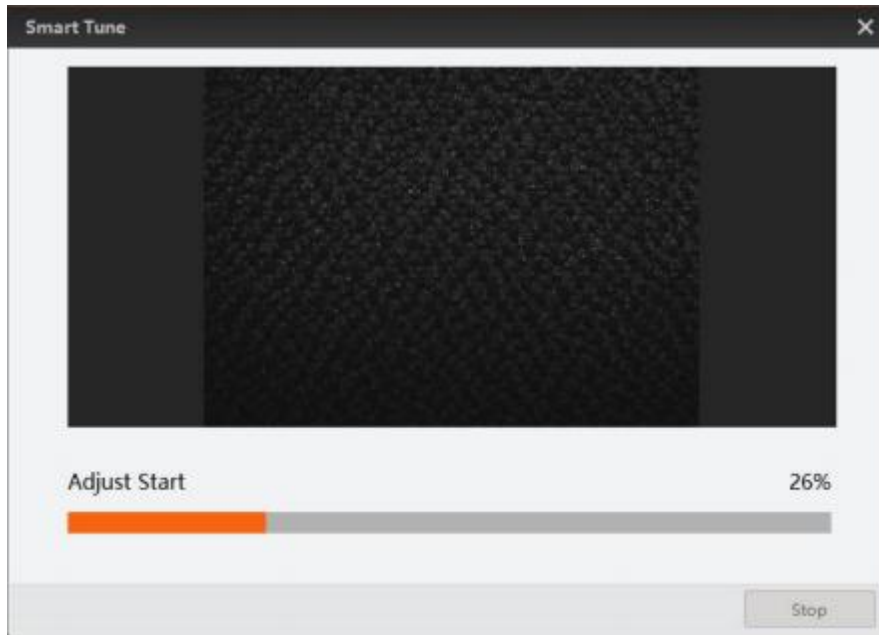

Figure 9-11 Smart Tune Start

4. (Optional) View smart tune process via **Smart Tune Status**.
5. Click **Execute** in **Stop Tune** to stop smart tune process.

9.3.5 Set Focus

The device supports the focus function according to the code position in the field of view. Currently, three types of focus are supported, including global auto focus, global manual focus, and ROI focus.

Note

- Make sure that the device's operation mode is test before performing focus, and switch to the normal operation mode after the focus is completed.
 - The focus function may differ by device models.
-

Global Auto Focus

The global autofocus allows you to adjust lens focus in a global field of view just by once.

Steps

1. Goto **Image Settings** → **Smart Tune Control** → **Focus Param** → **Focus Mode Selector**, and select **Whole Area Focus** as **Focus Mode Selector**.

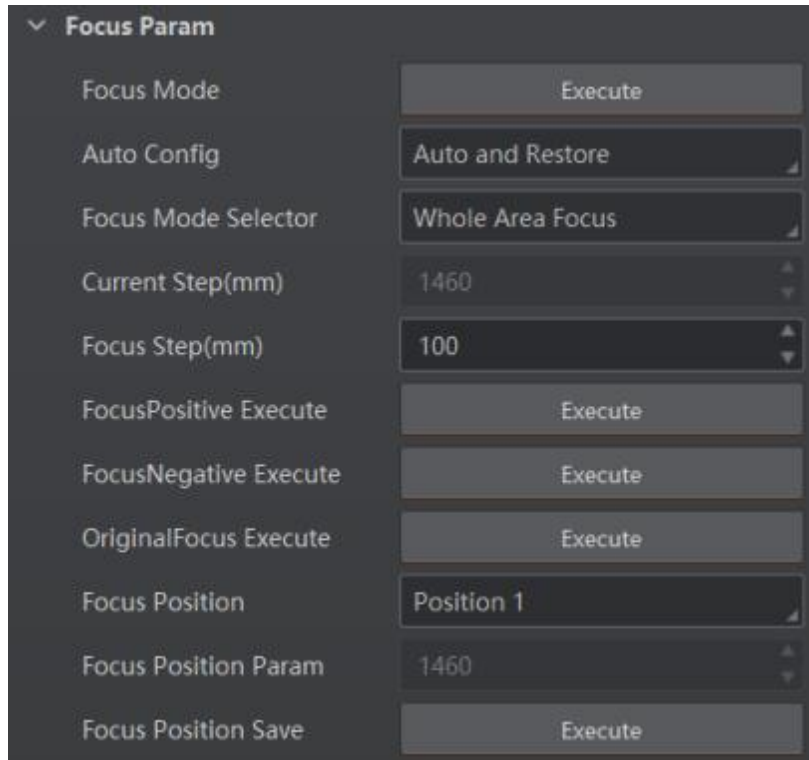



Figure 9-12 Global Auto Focus

2. Click  in the live view window, and click it again to stop acquisition and make sure there is an image in the window.
3. Select the focus mode in **Auto Config**:
 - **Full Auto**: In this mode, the device will automatically change parameters like focus position, exposure, gain, Gamma and light source when adjusting focus.
 - **Motor Only**: In this mode, the device will change focus position only when adjusting focus.
 - **Auto and Restore**: In this mode, the device will automatically change parameters like focus position, exposure, gain, Gamma and light source when adjusting focus, and keep focus position and restore other parameters after completing focus adjustment.
4. Click **Execute** in **Focus Mode**, and the device starts to adjust focus automatically.

 **Note**

Focus related parameters cannot be configured during auto focus process, and after the process, parameters can be configured again.

5. (Optional) Select the position parameter from **Focus Position**, and click **Execute** in **Focus Position Save** to save the focus position after adjusting focus.

Global Manual Focus

The global manual focus requires manual focus according to the images displayed in the live view window.

Steps

1. Goto **Image Settings** → **Smart Tune Control** → **Focus Param** → **Focus Mode Selector**, and select **Whole Area Focus** as **Focus Mode Selector**.
2. Click  in the live view window, and click it again to stop acquisition and make sure there is an image in the window.
3. Select **Focus Position** according to actual demands and **Focus Position Param**.
4. Set **Focus Step** according to actual demands.
5. Click **Execute** in **Focus Positive Execute** and **Focus Negative Execute** to adjust focus position.
6. (Optional) View **Focus Score** to know the score of the focus adjustment.
7. (Optional) Select the position parameter from **Focus Position**, and click **Execute** in **Focus Position Save** to save the focus position after adjusting focus.
8. (Optional) Click **Execute** in **Original Focus Execute** to let the focus back to its original position.

ROI Focus

The ROI focus allows you to adjust lens focus regarding the ROI area by drawing specific area.

Note

The ROI focus is applicable to the scenario where multiple codes with different depth of fields are existed.

Steps

1. Goto **Image Settings** → **Smart Tune Control** → **Focus Param** → **Focus Mode Selector**, and select **ROI Area Focus** as **Focus Mode Selector**.

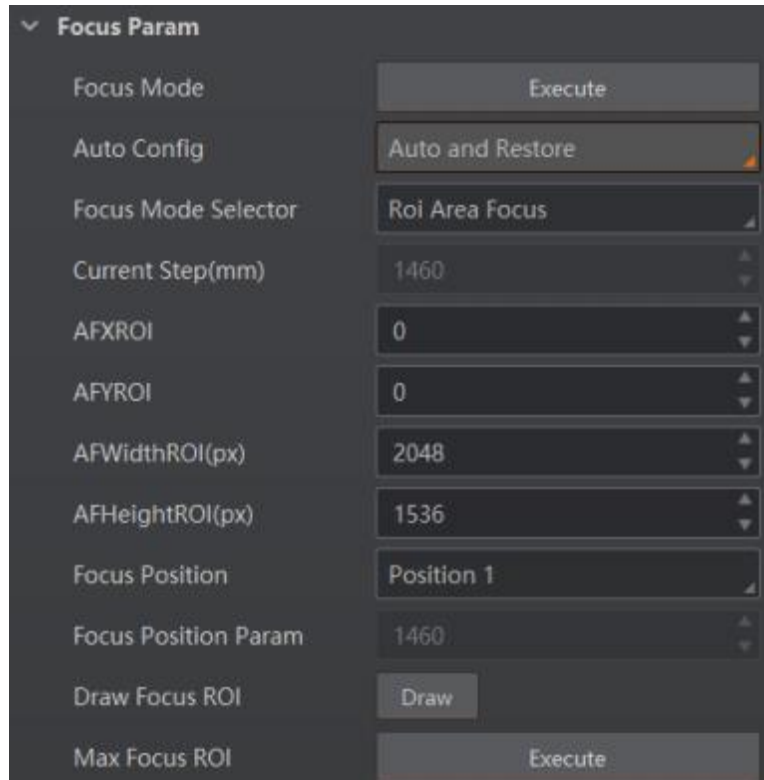

Figure 9-13 ROI Focus

2. Click  in the live view window, and click it again to stop acquisition and make sure there is image in the window.
3. Click **Draw** in **Draw Focus ROI**, and draw ROI by dragging the mouse in live view window.



Figure 9-14 Draw Focus ROI

4. (Optional) Set following parameters to adjust ROI size and position.
 - **AF Offsex X**: It is X coordinate of the upper left corner in ROI where executes autofocus.
 - **AF OffsexY**: It is Y coordinate of the upper left corner in ROI where executes autofocus.
 - **AF Width ROI**: It refers to the width in ROI where executes autofocus.
 - **AF Height ROI**: It refers to the height in ROI where executes autofocus.
5. (Optional) Click **Execute** in **Max. Focus ROI** to have a global focus.
6. (Optional) Repeat step 3 if you want to set multiple ROIs.

9.3.6 Set Self-Adaptive Adjustment

The function of self-adaptive adjustment can automatically adjust exposure, gain, Gamma and other parameters to have a better code reading effect.

 **Note**

The function of self-adaptive adjustment may differ by device models.

Steps

1. Go to **Image Settings** → **Smart Tune Control** → **Self Adapt Adjust**, and unfold **Self Adapt Adjust**.
2. Select **Adjust Source** according to actual demands.

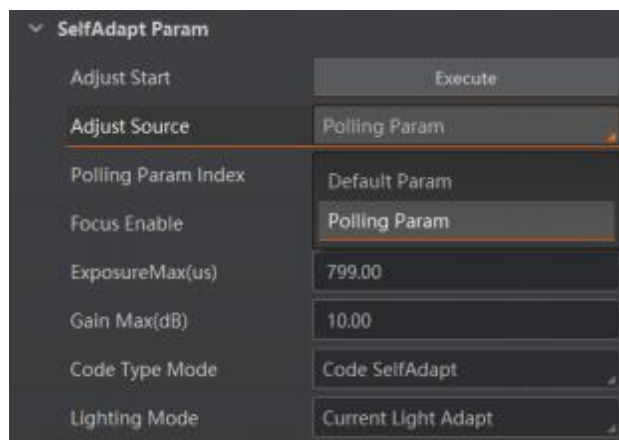

Figure 9-15 Select Adjust Source

- **Default Param:** It adjusts the default parameters.
- **Polling Param:** It adjusts parameters configured in polling. After **Polling Param** is selected as **Adjust Source**, you should select a polling parameter group from **Polling Param** and enable or disable **Focus Enable**.

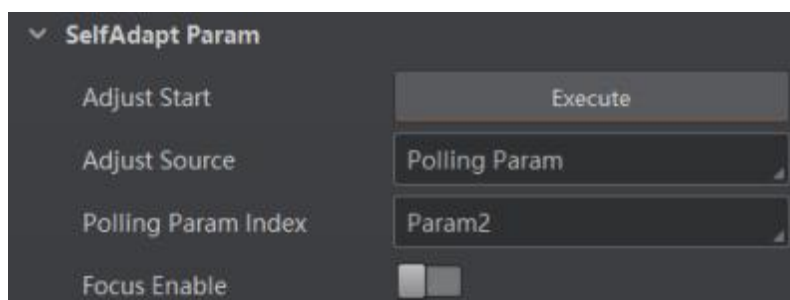

Figure 9-16 Polling Parameter

3. Set **Exposure Max** or **Gain Max** according to actual demands.
 - **Exposure Max:** It sets the max. exposure during the self-adaptive adjustment.
 - **Gain Max:** It sets the max. gain during the self-adaptive adjustment.
4. (Optional) Set self-adaptive code type in **Code Type Mode**.
 - **Code Self-Adaptive:** All code types added in field of view will be self-adaptive.

- **1D Code:** 1D code types added in field of view will be self-adaptive.
 - **2D Code:** 2D code types added in field of view will be self-adaptive.
 - **Stacked Code:** Stacked code types added in field of view will be self-adaptive.
5. (Optional) Set light source parameters in **Lighting Mode**.
- **Light Adapt:** The client software will select the best one from all lighting options during the self-adaptive adjustment.
 - **Current Light Adapt:** The client software will use the current configured light source.
 - **All Light Disable:** All light sources will be turned off during self-adaptive adjustment process.
6. Click **Execute** in **Adjust Start**. The device will automatically acquire images and perform self-adaptive adjustment, and stop acquisition after adjustment is completed.
-

Note

If the adjustment completed, the client software displays the spent time and prompts adjustment succeeded. If the adjustment failed or is timeout, the client software prompts adjustment failure or timeout.

9.3.7 Set Test Pattern

Test pattern helps troubleshooting image problems and images in the test pattern are only for test. When exceptions occur in images acquired by the device in realtime, you can check if images in the test pattern have similar problems to determine the cause of an exception.

Note

- The test pattern is available in the test or raw operation mode.
 - Specific parameters of this function may differ by device models.
-

Go to **Image Settings**, click **All Features**, find **Test Pattern** in **Other Features**, and set **Test Pattern** according to actual demands.

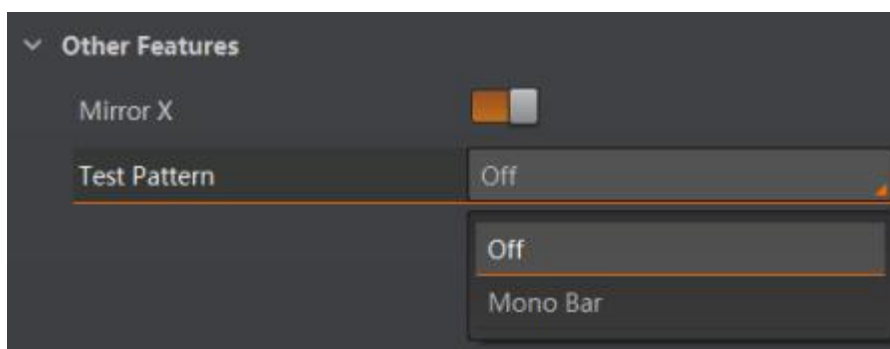

Figure 9-17 Set Test Pattern

9.4 Code Algorithm Settings

The code reader supports reading multiple types of 1D code, 2D code, and stacked codes, and you can add and set code parameters via the client software.

9.4.1 Add Code

Adding code before you set code parameters via the client software. In **Algorithm Settings**, you can add different types of codes according to actual demands.

In **Algorithm Settings**, click **Add Barcode**, select types of codes to be read, and set the **1D Code Number**, **2D Code Number**, and **Stack Bar Number** according to actual demands.

Note

- For different models of the device, the specific parameters may differ, and the actual device you purchased shall prevail.
 - Selected symbology amount and added code amount may affect the code recognition time. Note that selecting more symbologies or adding more codes may consume more time to recognize codes in the image.
 - No matter 1D code, 2D code or stacked code number, up to 20 codes can be added at a time. Note that adding more codes may consume more time to recognize codes in the image. Therefore, the code number is recommended to be set according to the actual demands.
 - The code reader may output actual code number when the mismatch between the actual code number and the code number set in the client software occurs.
-

9.4.2 Set Code Reading ROI

Algorithm ROI (Region of Interest) allows the device to execute algorithms and read codes on the specific area you selected, and thus improving code reading efficiency.

Currently, multiple ROIs can be configured, and the device outputs codes according to the number of ROI (e.g. Region 1, Region 2, and Region 3...) in turn. The client software supports drawing single group of ROI and drawing ROI via chessboard.

Note

- If no code is recognized in the algorithm ROI, and the device will output “noread”.
 - Before drawing ROIs, make sure that there are images in the live view window after stopping preview.
 - If no algorithm ROI is enabled, and the full screen is the algorithm ROI by default.
 - This function may differ by device models.
-

Draw Single Group of ROI

Steps

1. Goto **Algorithm Settings**, and find **Algorithm ROI**.
2. Click **Draw** in **Draw ROI** to draw ROI in the live view window.



Figure 9-18 Draw ROI

3. (Optional) Repeat the above step to draw multiple ROIs according to actual demands.

Note

The client software only parse codes in the ROI you drawn.

4. (Optional) Set other ROI parameters according to actual demands.
 - **ROI Index**: It indicates different ROIs and ranges from 0 to 149 corresponds 1 to 150 ROIs.
 - **Algo Region Left X**: It refers to the X coordinate of the upper left corner in algorithm ROI.
 - **Algo Region Left Y**: It refers to the Y coordinate of the upper left corner in algorithm ROI.
 - **Algo Region Width**: It refers to the width in algorithm ROI.
 - **Algo Region Height**: It refers to the height in algorithm ROI.
5. (Optional) Click **Execute** in **Restore Max. Algorithm ROI** to restore the ROI to the full screen.
6. (Optional) Click **Execute** in **Clear All ROI** to delete all ROIs.

Draw ROI via Chessboard

Steps

1. Goto **Algorithm Settings**, and find **Algorithm ROI**.
2. Click **Execute** in **Chessboard ROI**, set parameters, and click **OK** after setting.

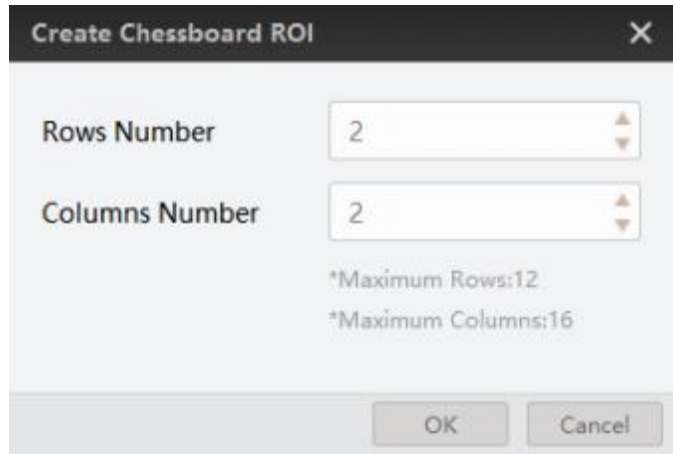

Figure 9-19 Create Chessboard ROI

3. Click after creating ROI, and the red frame becomes green as shown below.



Figure 9-20 Draw ROI via Chessboard

4. (Optional) Click to restore the ROI to full screen, and click to clean all ROIs.

5. Repeat other optional steps mentioned in drawing single group of ROI.

 **Note**

The figures above are for reference only, and refer to the actual conditions.

9.4.3 Set Algorithm Parameter

In **Algorithm Parameter**, select **1DCode**, **2DCode** or **Stacked Code** as **Arithmetic Type**, and then you can set its corresponding parameters.

 **Note**

- You should have selected at least one type of 1D code, 2D code or stacked code.
 - For different models of the device, the specific parameters may differ, and the actual device you purchased shall prevail.
-

Set 1D Code

- **Timeout Value:** Timeout value refers to the maximum running time of algorithm, and its unit is ms. The code reader will stop parsing the images and return results if the time is exceeded the waiting time configured.
 - **Code Color:** It defines the readable code color. **White Code On Black Wall** means that the client software can recognize the white code with black background. **Black Code On White Wall** means that the client software can recognize the black code with white background. **Adaptive** means that the client software can recognize both the black code with white background, and the white code with black background.
 - **Code 39 Check:** Enable this parameter if Code 39 uses the parity bit.
-

Note

You need to select **Code 39** in **Add Barcode**.

- **ITF 25 Check:** Enable this parameter if ITF 25 uses the parity bit.
-

Note

You need to select **ITF 25** in **Add Barcode**.

- **1D Code Quality Enable:** If it is enabled, the client software will judge the quality of 1D code and output overall grade. Currently, this parameter is only applicable to Code 39 and Code 128.
- **Code Score Enable:** If it is enabled, the client software will evaluate the code reading environment for 1D code and output code score.

Set 2D Code

- **Timeout Value:** Timeout value refers to the maximum running time of algorithm, and its unit is ms. The code reader will stop parsing the images and return results if the time is exceeded the waiting time configured.
- **Algorithm Running Mode:** It is used to be set the algorithm operating mode. It includes **High Speed**, **High Performance**, and **Balance**. **High Speed** focuses on recognition speed, and the algorithm can recognize the code rapidly, while **High Performance** refers to the algorithm can recognize the code that has distortion, spot or white gap, but its recognition speed is slow. **Balance** refers to the algorithm makes a balance between speed and performance.
- **2D Code Max. Size:** It refers to the max. recognizable code width. The 2D code will not be recognized if its width exceeds the configured value.
- **Mirror Mode:** It is useful when the recognized image is a mirror one, mirroring in X coordinate. 3 modes are available: **Adaptive**, **Mirror**, and **Non Mirror**.
- **Downsampling Level:** It refers to the pixel sample size that the code reader takes. Increasing this parameter will improve the code reading efficiency at the expense of code recognition rate.

 **Note**

Increasing this parameter value will improve the code reading efficiency at the cost of code recognition rate.

- **Code Color:** It defines the readable code color. **Adaptive** means that the client software can recognize both the black code with white background, and the white code with black background. **White Code On Black Wall** means that the client software can recognize the white code with black background. **Black Code On White Wall** means that the client software can recognize the black code with white background.
-

 **Note**



- For QR code, the code color is determined by the color of the concentric square on it.  indicates that the code color is white, and  indicates that the code color is black.



Figure 9-21 White QR Code



Figure 9-22 Black QR Code





- For DM code, the code color is determined by the color of its "L" shaped sides. White "L" shaped sides indicate that the code color is white, and black "L" shaped sides indicate that the code color is black.



Figure 9-23 White DM Code



Figure 9-24 Black DM Code

- **Discrete Flag: Continuous** stands for the minimum units in the "L" shaped sides of the DM code are continuous, or the minimum units in the concentric square like  or  in the QR code are continuous. Usually the continuous code uses squares as the minimum units. **Discrete** stands for the minimum units in the "L" shaped sides of the DM code are discrete, or the minimum units in the concentric square like  or  in the QR code are discrete. Usually the discrete code uses dots as the minimum units. **Adaptive** stands for the device can recognize both continuous code and the discrete code.
 - **QR Distortion Correction:** If the QR code or DM code is distorted, you can enable this parameter to improve code recognition rate.
-

 **Note**

If you enable this parameter, the more time will be consumed to recognize the codes in the image.

- **DM Code Shape:** It defines the recognizable code shape. **Square** stands for square mode: If the 2D code is square shaped, it can be recognized by the device. **Rectangle** stands for rectangle mode: If the 2D code is rectangle shaped, it can be recognized by the device. **Adaptive** stands for compatible mode: The device can recognize 2D codes of both the above-mentioned two shapes.
 - **DM Code Type:** It includes **All**, **ECC140**, and **ECC200**.
 - **2D Code Quality Enable:** Refer to section **Set 2D Code Quality Evaluation** for details.
 - **Code Score Enable:** If it is enabled, the device will evaluate code quality and display overall grade and code score in history record area of the client software. The higher the score, and the better the code quality.
 - **Accurate Timeout Enable:** If it is enabled, the accuracy of algorithm timeout will improve.
-

Set Stacked Code

Code Score Enable: If it is enabled, the client software will evaluate the code reading environment for stacked code and output code score.

9.4.4 Set Code Quality Evaluation

The code quality evaluation function judges the quality of codes and outputs overall grade. Currently, only 1D code and 2D code support code quality evaluation.

Note

- The function of code quality evaluation may differ by device models.
 - In test operation mode, this function is enabled by default. In normal mode, you need to enable it manually.
-

Set 1D Code Quality Evaluation

The 1D quality evaluation function uses the ISO15416 standard to judges the quality of codes and outputs overall grade. Currently, this function is only applicable to Code 39 and Code 128.

Steps

1. Goto **Algorithm Control** → **Algorithm Parameter**, and select **1D Code** as **Arithmetic Type**.
2. Enable **1D Code Quality Evaluation**.
3. Enable different quality evaluation standards according to actual demands.

Table 9-6 Quality Evaluation Standards

| Parameter | Description |
|-----------------------|---|
| Decodability | It evaluates whether the code has enough basic information to be decoded. |
| Symbol Contrast | It evaluates the difference between the max. brightness value and the min. brightness value of the code area. |
| Modulation | It evaluates the degree of change in terms of brightness. |
| Edge Determination | It evaluates how well the number of edges read by the code matches the configured number of edges. |
| Minimum Reflectance | It evaluates the ratio of the min. brightness value to the max. brightness value. |
| Minimum Edge Contrast | It evaluates the min. value of the reflectivity difference of the strip connecting the spaces. |
| Decode Enable | It evaluates whether the code recognition is successful or not. |
| Defects | It evaluates codes or spaces for defects or dirt. |

| Parameter | Description |
|------------|--|
| Quiet Zone | It evaluates the quite zone width of the code meets the specification. |

4. Set the evaluation value for A/B/C/D grade according to actual demands.

Note

- If the actual code reading value of the device is greater than the grade A evaluation value, and then the evaluation standard is grade A. If the actual code reading value is between grade A and grade B, and then the evaluation standard is grade B. If the actual code reading value is between grade B and grade C, and then the evaluation standard is grade C. If the actual code reading value is between grade C and grade D, and then the evaluation standard is grade D. If the actual code reading value is lower than the D grade, and then the evaluation standard is F grade.
- The client software selects the worst grade among all the evaluation standards as the grade judgment result of the code. The A grade means that the code quality is best, and F grade means that code quality is worst.

5. Enable **Aperture Enable** and enter **Aperture** according to the smallest size of codes.
6. (Optional) Set **Quality 1D Max Num** to configure the amount of code to be evaluated. If the actual amount of code exceeds the configured, the later codes will not be evaluated.
7. (Optional) Go to **Algorithm Control** → **Rating Standard 1D Enable**, set enable **Rating Standard 1D Enable**, and select **1D Rating Standard**.

Note

For example, if **1D Rating Standard** is **C**, and then the client software will output codes with A/B/C grade and codes with D/F will be filtered.

7. Click  to start acquisition, and the client software will display the overall code quality in the history record area.

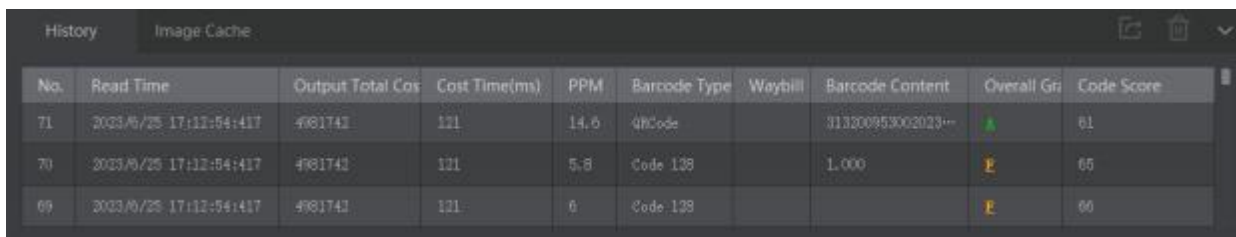

| No. | Read Time | Output Total Cos | Cost Time(ms) | PPM | Barcode Type | Waybill | Barcode Content | Overall Gr | Code Score |
|-----|------------------------|------------------|---------------|------|--------------|---------|---------------------|------------|------------|
| 71 | 2023/6/25 17:12:54:417 | 4981742 | 121 | 14.6 | 4hCode | | 3113200953002023--- | A | 61 |
| 70 | 2023/6/25 17:12:54:417 | 4981742 | 121 | 5.8 | Code 128 | | L 000 | B | 66 |
| 69 | 2023/6/25 17:12:54:417 | 4981742 | 121 | 6 | Code 128 | | | B | 66 |

Figure 9-25 Overall Code Quality

Set 2D Code Quality Evaluation

The 2D quality evaluation function uses the ISO15415 standard to judges the quality of

codes and outputs overall grade.

Note

- The specific parameters may differ by device models and firmware versions.
 - Make sure that the device's operation mode is normal and 2D codes added.
-

Steps

1. Goto **Algorithm Control** → **Algorithm Parameter**, and select **2D Code** as **Arithmetic Type**.
2. Enable **2D Code Quality Evaluation**.
3. Set **Iso Edition**, including **Iso15415** and **Iso29158**
 - Iso15415 is applicable to the quality evaluation for label 2-dimensional codes.
 - Iso29158 is applicable to the quality evaluation for DPM format 2-dimensional codes.
4. Refer to step 5 to step 7 in **Set 1D Code Quality Evaluation** to set other parameters.

9.4.5 Set Code Score

The code score function evaluates the code-reading environment for codes and outputs code score.

Note

- The function of code score may differ by device models.
 - In test mode, this function is enabled by default. In normal mode, you need to enable it manually.
 - The code score is determined by two factors including image quality and print quality of codes. The range of code score is between 0 and 100, and the higher the score, and easier the code can be read.
-

Steps

1. Goto **Algorithm Settings**, and enable **Code Score Enable**.

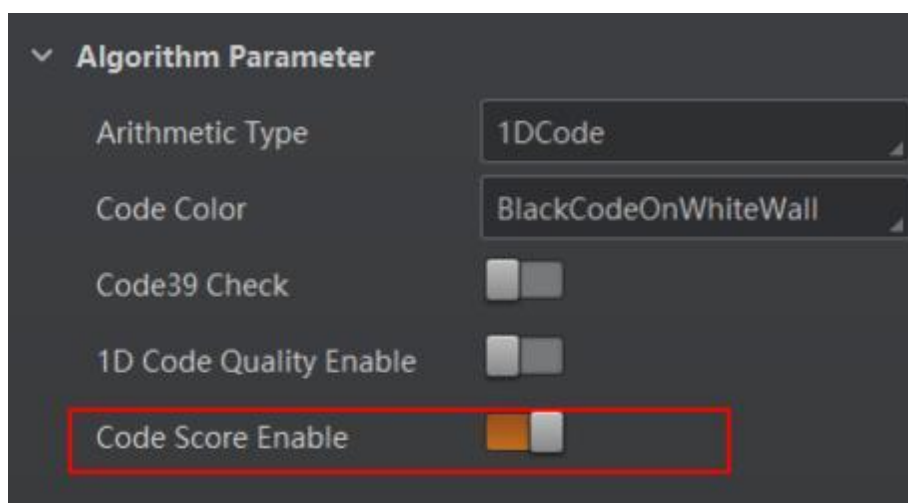

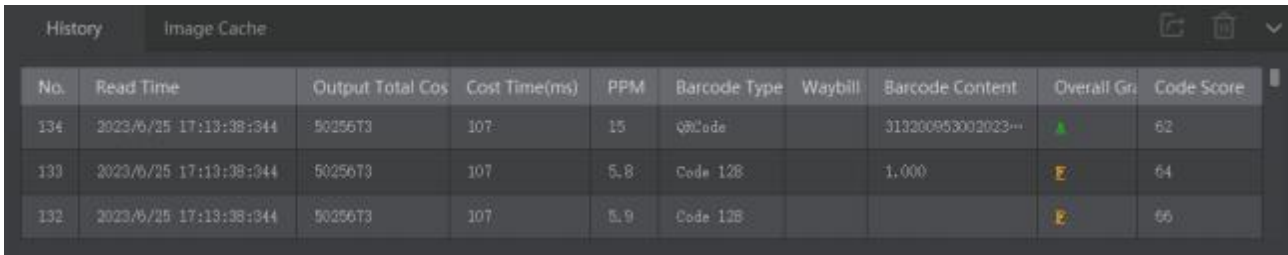

Figure 9-26 Enable Code Score Enable

2. Click  to start acquisition, and the client software will display specific code score in the history record area.





| No. | Read Time | Output Total Cos | Cost Time(ms) | PPM | Barcode Type | Waybill | Barcode Content | Overall Gr. | Code Score |
|-----|------------------------|------------------|---------------|-----|--------------|---------|--------------------|---|------------|
| 134 | 2023/6/25 17:13:38:344 | 5025673 | 107 | 15 | QRCode | | 313200953003023... |  | 62 |
| 133 | 2023/6/25 17:13:38:344 | 5025673 | 107 | 5.8 | Code 128 | | 1.000 |  | 64 |
| 132 | 2023/6/25 17:13:38:344 | 5025673 | 107 | 5.9 | Code 128 | | |  | 66 |

Figure 9-27 Code Score

3. (Optional) Goto **Image Settings**, and adjust parameters like exposure time, gain, Gamma, light source, etc. if the code score is low.

Note

If the code score is still low after adjusting, and the code may have poor printing quality.

9.5 Line Mode Settings

Line mode settings allow you to customize the specific line as input or output according to actual demands.

Go to **I/O Control Settings** → **Line Mode Control**, and set **Input** or **Output** according to actual demands.

Note

- Only the vari focal device (type I, type II and type III devices) supports this function.
- If the device has 4 bi-directional I/Os, and Line 0 and Line 1 are input, and Line 2 and Line 3 are output by default.
- Line 0 should be same with Line 1 as input or output, and Line 2 should be same with Line 3 as input or output.

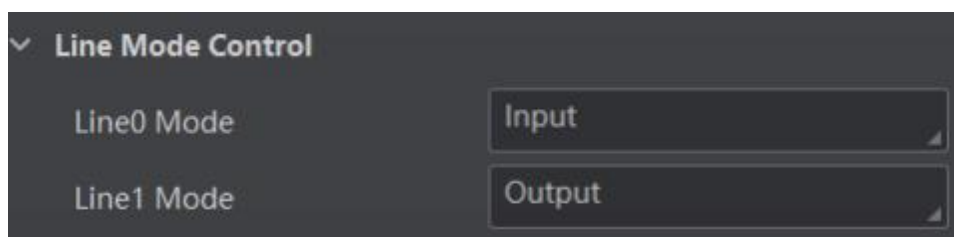

Figure 9-28 Set Line Mode

9.6 Signal Input Settings

In the signal input module, you can set the trigger related parameters. You can enable trigger mode to let the acquisition of image data occur only when the trigger source is generated.

9.6.1 Set Trigger Mode

The device has 2 types of trigger mode: Internal trigger mode and external trigger mode.

- **Internal Trigger Mode:** The device acquires images via its internal signals.
- **External Trigger Mode:** The device acquires images via external signals like software signal and hardware signal. The trigger source of external trigger mode includes software, physical lines, counter, TCP, UDP, etc.

Note

- Type VII device supports software, physical lines (LineIn 1 and Line 2), response trigger and self trigger.
 - Regarding other device types, the device with USB data interface supports two trigger sources (USB stat and software) only, and the device with fast Ethernet supports all trigger sources apart from USB stat.
 - For specific trigger sources, refer to the actual device you got.
 - The device trigger via pressing trigger button is supported by default. You can go to **Feature Tree** → **Trigger and IO Control** → **TRIG Button Enable** to disable it.
-

9.6.2 Enable Internal Trigger Mode

In the internal trigger mode, the device acquires images via its internal signals. You have 2 methods to enable the internal trigger mode:

- Click **I/O Control Settings** → **Input** → **Trigger Mode**, and select **Off** as **Trigger Mode**.
- In the live view page, click  to enable the internal trigger mode.

9.6.3 Enable External Trigger Mode

In the external trigger mode, the device acquires images via external signals like software signal and hardware signal. You have 2 methods to enable the external trigger mode:

- Click **I/O Control Settings** → **Input** → **Trigger Mode**, and select **On** as **Trigger Mode**.
- In the live view page, click  to enable the external trigger mode.

Set and Execute Software Trigger Mode

In software trigger, the software sends trigger signal to the device via I/O interface to acquire images.

Steps

1. Click **I/O Control Settings** → **Input** → **Trigger Mode**.
2. Select **On** as **Trigger Mode**.
3. Select **Software** as **Trigger Source**.
4. Click **Execute** in **Trigger Source** to send trigger commands.

You can also enter **Auto Trigger Time**, and then enable **Enable Auto Trigger** to let the client software automatically send trigger signal to device according to the interval you set.

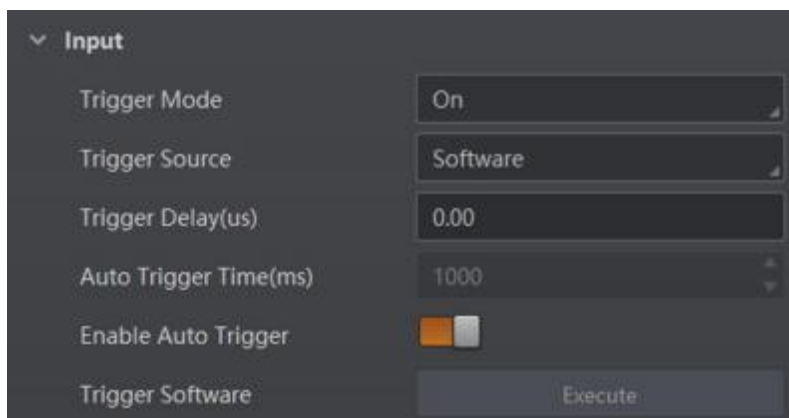

Figure 9-29 Set and Execute Software Trigger Mode

Set and Execute Hardware Trigger Mode

Steps

1. Click **I/O Control Settings** → **Input** → **Trigger Mode**.
2. Select **On** as **Trigger Mode**.
3. Select the specific line as **Trigger Source** according to actual demands.

Note

For the vari focal device (type I, type II and type III devices), you can select customized lines as **Trigger Source**. Refer to section **Line Mode Settings** for specific settings.

4. Set **Debounce Time** and **Line Out Trigger In Polarity** according to actual demands.
-

Note

- When selecting **Rising Edge** or **Falling Edge** as **Line Out Trigger In Polarity**, you can set **Trigger Delay**.
 - When selecting **Level High** or **Level Low** as **Line Out Trigger In Polarity**, you can set **Start Delay Time** and **End Delay Time** according to actual demands.
-

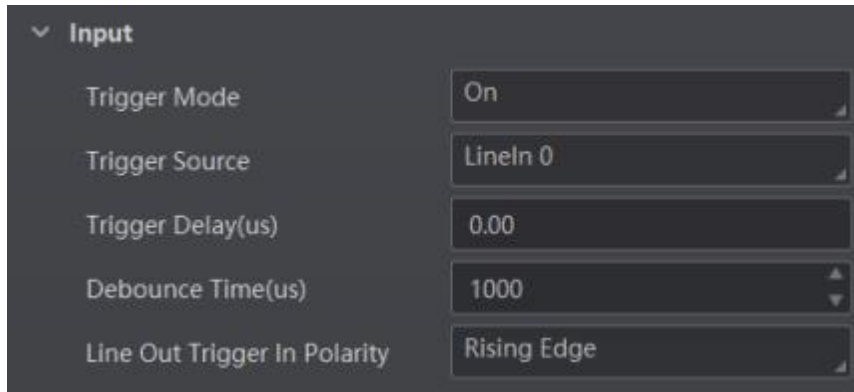

Figure 9-30 Set and Execute Hardware Trigger Mode

Set and Execute Counter Trigger Mode

Counter specifies that the trigger source will be generated after the set number of valid signals appears. For example, if you set the **Count Number** to **3**, the trigger source will be generated after 3 signals appear.

Steps

1. Click **I/O Control Settings** → **Input** → **Trigger Mode**.
2. Select **On** as **Trigger Mode**.
3. Select **Counter 0** as **Trigger Source**.
4. Set **Trigger Delay**, **Count Number**, **Count Source** and **Line Out Trigger In Polarity** according to actual demands.

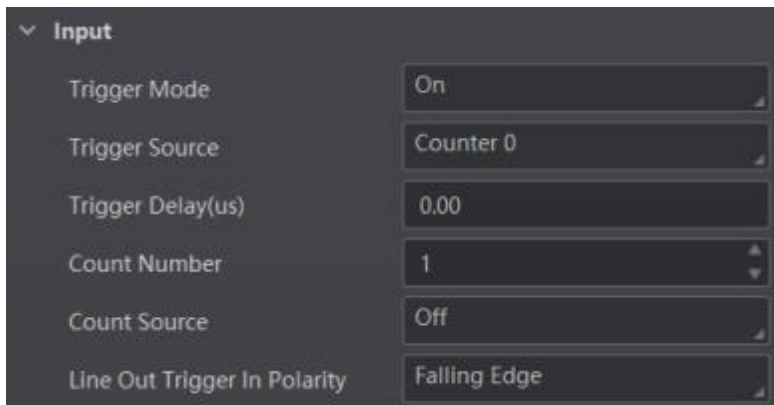

Figure 9-31 Set and Execute Counter Trigger Mode

Set and Execute TCP Trigger Mode

TCP start specifies the TCP server as the source for the trigger signal. When the server receives the specified string text, the trigger signal will be outputted.

Steps

1. Goto **I/O Control Settings** → **Input** → **Trigger Mode**.

2. Select **On** as **Trigger Mode**.
3. Select **TCP Start** as **Trigger Source**.
4. Set following parameters according to actual demands.
 - **TCP Trigger Port**: It sets the host port of TCP trigger.
 - **TCP Start Trigger Text**: It sets the trigger text of TCP start, and it is **Start** by default.

Set and Execute UDP Trigger Mode

UDP start specifies the UDP server as the source for the trigger signal. When the server receives the specified string text, the trigger signal will be outputted.

Steps

1. Goto **I/O Control Settings** → **Input** → **Trigger Mode**.
2. Select **On** as **Trigger Mode**.
3. Select **UDP Start** as **Trigger Source**.
4. Set following parameters according to actual demands.
 - **UDP Trigger Port**: It sets the host port of UDP trigger.
 - **UDP Start Trigger Text**: It sets the trigger text of UDP start, and it is **Start** by default.

Set and Execute Serial Port Trigger Mode

Serial start specifies the serial port as the source for the trigger signal. When the serial port receives the specified string text, the trigger signal will be outputted.

Steps

1. Goto **I/O Control Settings** → **Input** → **Trigger Mode**.
2. Select **On** as **Trigger Mode**.
3. Select **Serial Start** as **Trigger Source**.
4. Set **Serial Baudrate**, **Serial Data Bits**, **Serial Parity**, and **Serial Stop Bits**.
5. Set **Serial Start Trigger Text** that configures the trigger text of serial port start, and it is **Start** by default.

Set and Execute USB Trigger Mode

Steps

1. Goto **I/O Control Settings** → **Input** → **Trigger Mode**.
2. Select **On** as **Trigger Mode**.
3. Select **USB Start** as **Trigger Source**.
4. Set **USB Baudrate**, **USB Data Bits**, **USB Parity**, **USB Stop Bits**, and **USB Start Trigger Text** according to actual demands.

Set and Execute Self Trigger Mode

Self trigger allows you to trigger the device according to the trigger period you configured.

Steps

1. Click **I/O Control Settings** → **Input** → **Trigger Mode**.
2. Select **On** as **Trigger Mode**.
3. Select **Self Trigger** as **Trigger Source**, set **Self Trigger Period** and **Self Trigger Count**.

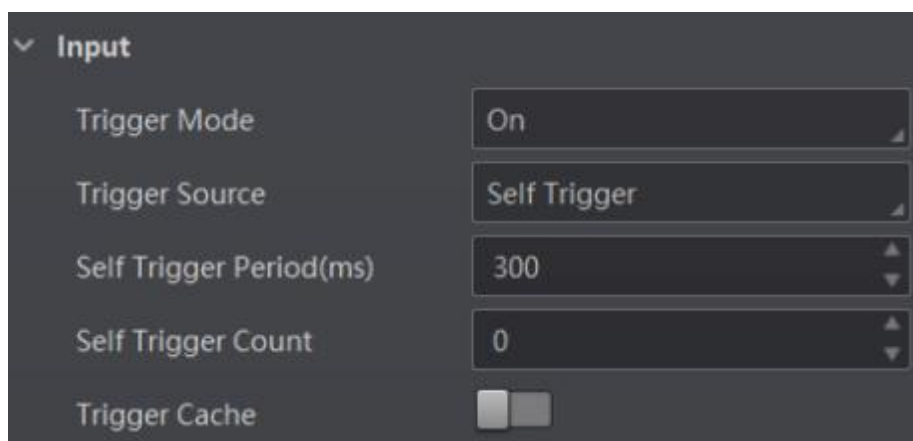

Figure 9-32 Set and Execute Self Trigger Mode

Note

- If the self-trigger count is set to 0, and it means that it can be triggered indefinitely until the execution of self-trigger stops.
 - The self-trigger timeshall be set to be greater than the reciprocal of the actual frame rate.
-

Set and Execute Response Tigger

Steps

1. Click **I/O Control Settings** → **Input** → **Trigger Mode**.
2. Select **On** as **Trigger Mode**.
3. Select **Response Trigger** as **Trigger Source**, and set **Trigger Sensitivity** accordingly.

9.6.4 Stop Trigger

The device supports stopping trigger via TCP, UDP, I/O, serial port and USB. You can also set code reading timeout duration or max. code amount to be read to stop trigger. After stopping trigger is completed, the device cannot make response to trigger again.

Note

- Type VII device supports stopping trigger via serial port, I/O, code reading timeout duration or max. code amount.
-

- Regarding other device types, the device with USB data interface supports stopping trigger via USB only, and the device with fast Ethernet supports all stop trigger methods apart from USB method.
 - For specific stop trigger methods, refer to the actual device you got.
-

Stop Trigger via TCP

When the TCP server receives the specified string text, the trigger will be stopped.

Steps

1. Goto **I/O Control Settings** → **Stop Trigger**.
2. Enable **TCP Stop Trigger Enable**.
3. Set following parameters according to actual demands.
 - **TCP Trigger Port**: It is 2001 by default.
 - **TCP Stop Trigger Format**: It is **Str** by default.
 - **TCP Stop Trigger Text**: It sets the stop trigger text, and it is **Stop** by default.

Stop Trigger via UDP

When the UDP receives the specified string text, the trigger will be stopped.

Steps

1. Goto **I/O Control Settings** → **Stop Trigger**.
2. Enable **UDP Stop Trigger Enable**.
3. Set following parameters according to actual demands.
 - **UDP Trigger Port**: It is 2002 by default.
 - **UDP Stop Trigger Format**: It is **Str** by default.
 - **UDP Stop Trigger Text**: It sets the stop trigger text, and it is **Stop** by default.

Stop Trigger via IO

Stopping trigger via IO allows you to select hardware or software trigger source to stop the device from acquiring images.

Steps

1. Goto **I/O Control Settings** → **Stop Trigger**.
2. Enable **IO Stop Trigger Enable**.
3. Select sources from **LineIn 0/1/2/3** and **Software Trigger End** as **IO Stop TriggerSelector**.
4. (Optional) Set trigger activation if **LineIn 0/1/2/3** is selected as **IO Stop Trigger Selector**.
5. (Optional) Click **Execute** in **Software Stop Trigger** to stop trigger if **Software Trigger End** is selected as **IO Stop Trigger Selector**.

Stop Trigger via Serial Port

When the specified serial port receives the specified string text, the trigger will be stopped.

Steps

1. Goto **I/O Control Settings** → **Stop Trigger**.
2. Enable **Serial Stop Trigger Enable**.
3. Set following parameters according to actual demands.
 - **Serial Stop Trigger Text**: It sets the trigger text of serial port stop, and it is **Stop** by default.
 - **Serial Baud Rate**: It sets the baud rate of the serial port, and it is 9600 by default.
 - **Serial Data Bits**: It sets the data bits of the serial port, and it is 8 by default.
 - **Serial Parity**: It sets the parity of the serial port, and it is **No Parity** by default.
 - **Serial Stop Bits**: It sets the stop bits of the serial port, and it is 1 by default.

Stop Trigger via USB

The USB stop trigger function means that the device receives USB commands from the external device to stop image acquisition. At this time, the device acts as a USB server to receive commands, and the external device communicating with it acts as a USB client to send commands.

Goto **Feature Tree**, find **Stop Trigger Control**, enable **USB Stop Trigger Enable**, set **USB Stop Trigger Text**, **USB Baudrate**, **USB Data Bits**, **USB Parity**, and **USB Stop Bits** according to actual demands.

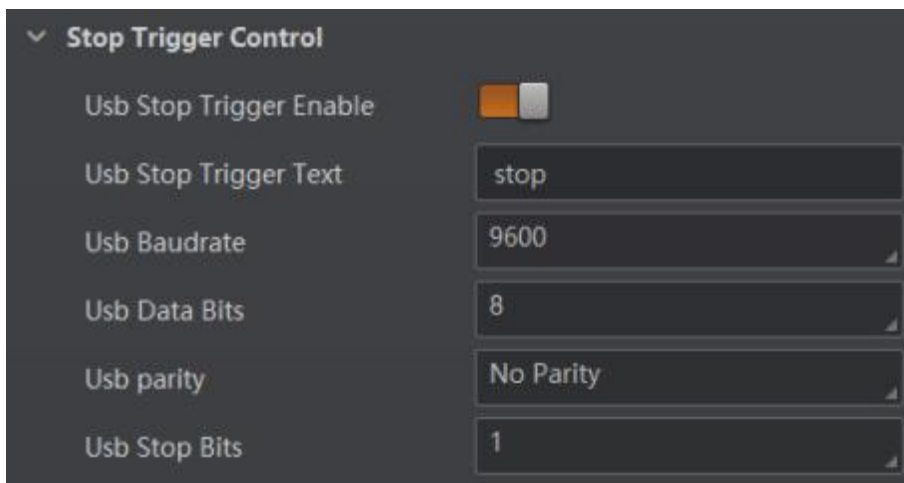

Figure 9-33 Stop Trigger via USB

Stop Trigger via Timeout Duration

When the trigger time reaches the specified maximum value (ms), the trigger will be stopped. You can enable **TimeOut Stop Trigger Enable**, and set **Maximum Output Limited Time**

according to actual demands.

 **Note**

The range of **Maximum Output Limited Time** is between 0 ms and 10000 ms.

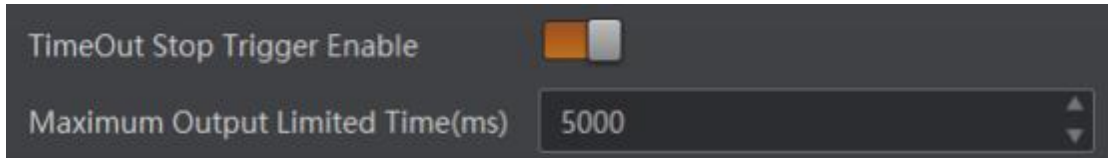

Figure 9-34 Stop Trigger via Timeout Duration

Stop Trigger via Code Number

This function means that the code quantity outputted by the device is restricted to the settings you configured here.

You can enable **CodeNum Stop Trigger Enable**, and set **CodeNum Stop Trigger Min** and **CodeNum Stop Trigger Max** according to actual demands.

Note

- If the outputted code quantity is smaller than configured **CodeNum Stop Trigger Min**, and the device will output codes continuously.
 - If the outputted code quantity is smaller than configured **CodeNum Stop Trigger Max**, and the device will stop outputting codes.
 - If the outputted code quantity is between configured **CodeNum Stop Trigger Min** and **CodeNum Stop Trigger Max**, and the device will read and output codes according to trigger signals.
 - If **CodeNum Stop Trigger Min** is same with **CodeNum Stop Trigger Max**, and the device will stop outputting codes when the number of outputted codes reaches the configured number.
-

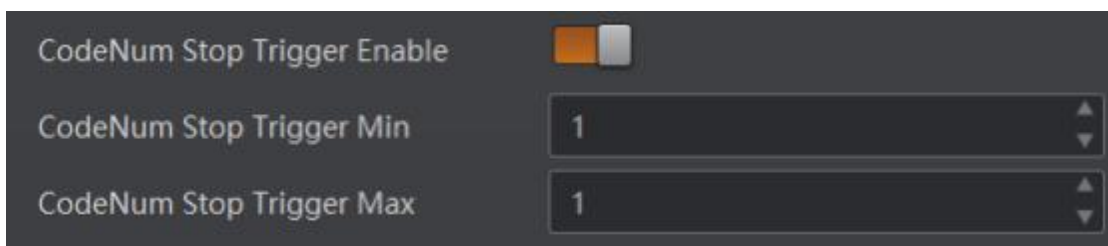

Figure 9-35 Stop Trigger via Code Number

9.7 Signal Output Settings

9.7.1 Select Output Signal

The device's output signal can control external devices like PLC, flashing light, etc. Click **I/O Control Settings** → **Output** → **Line Out Selector** to select output signal.

 **Note**

The specific output signals may differ by device models.

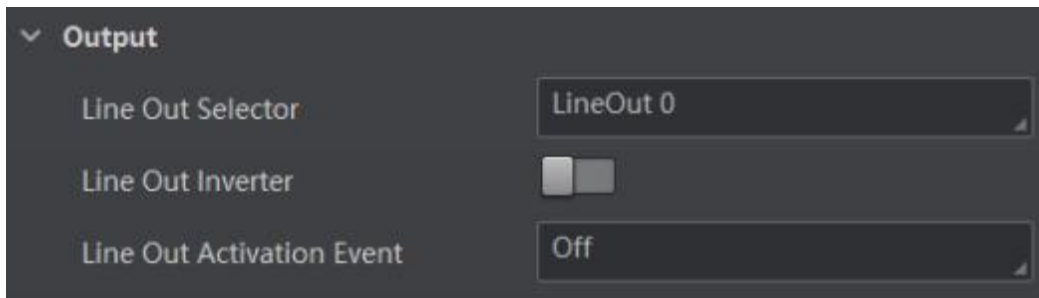

Figure 9-36 Select Output Signal

9.7.2 Enable Line Inverter

The line inverter function allows the device to invert the electrical signal level of an I/O line, and meets requirements of different devices for high or low electrical signal level. You can go to **I/O Control Settings** → **Output** → **Line Out Inverter** to enable it.

 **Note**

The **Line Out Inverter** function is disabled by default.

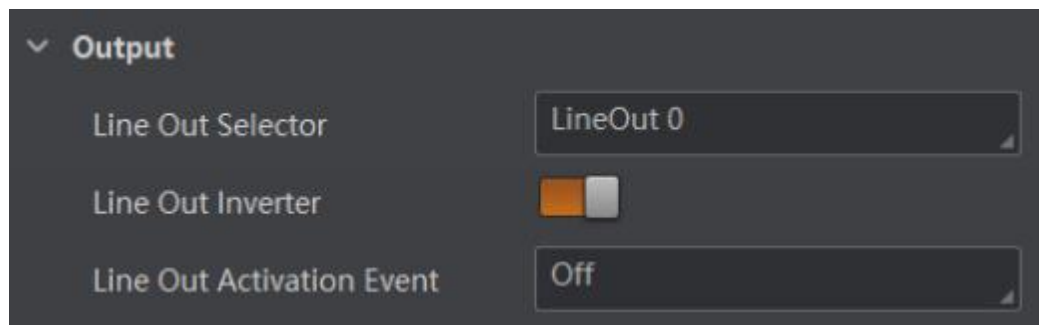

Figure 9-37 Enable Line Out Inverter

9.7.3 Set Event Source

The device supports outputting different trigger signals according to the event source you select. Click **I/O Control Settings** → **Output** → **Line Out Activation Event** to select event source.

The device supports following event sources, including **Off**, **NoCodeRead**, **ReadSuccess**, **Compare Success**, and **Compare Fail**.

Note

- **Off** refers to no event source.
- The event source parameters may differ by device model.
- **No Code Read**: If no code read by the device, the output signal will be triggered.
- **Read Success**: If the code is read by the device, the output signal will be triggered.
- **Compare Success**: If data comparison is successful, the output signal will be triggered.
- **Compare Fail**: If data comparison is failed, the output signal will be triggered.
- **Command Control IO**: It is controlled by the communication strings.

Note

You need to set different parameters when selecting these event sources.

Select No Code Read

If you select **No Code Read** as **Line Out Activation Event**, and you can set its output delay time and duration.

- **Line Out Delay Time**: It sets the delay time for outputting the output signal.
- **Line Out Duration**: It sets the time duration of the output signal.

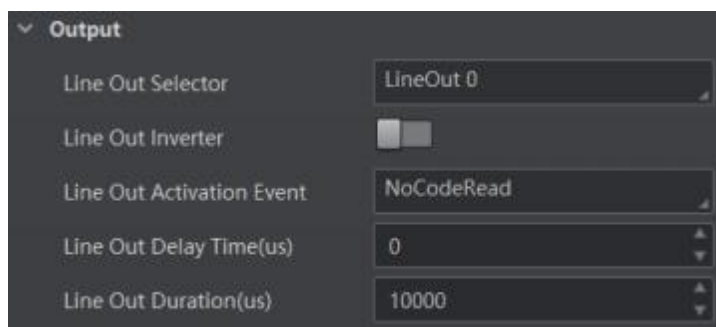

Figure 9-38 Select No Code Read

Select Read Success

If you select **Read Success** as **Line Out Activation Event**, and you can set its output delay time and duration.

- **Line Out Delay Time**: It sets the delay time for outputting the output signal.
- **Line Out Duration**: It sets the time duration of the output signal.

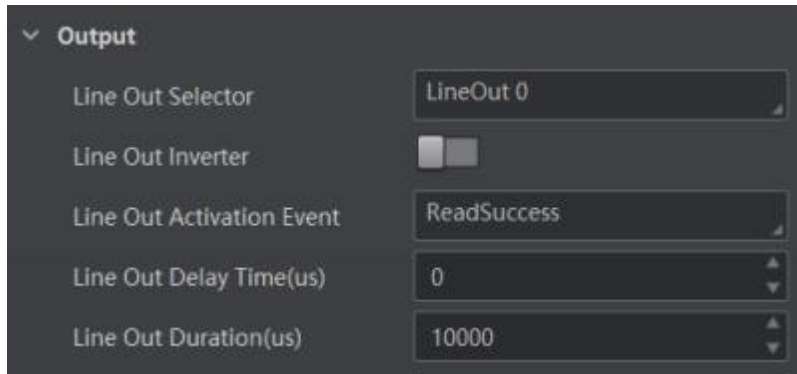

Figure 9-39 Select Read Success

Select Compare Success

If you select **Compare Success** as **Line Out Activation Event**, and you can set its output delay time and duration.

- **Line Out Delay Time:** It sets the delay time for outputting the output signal.
- **Line Out Duration:** It sets the time duration of the output signal.

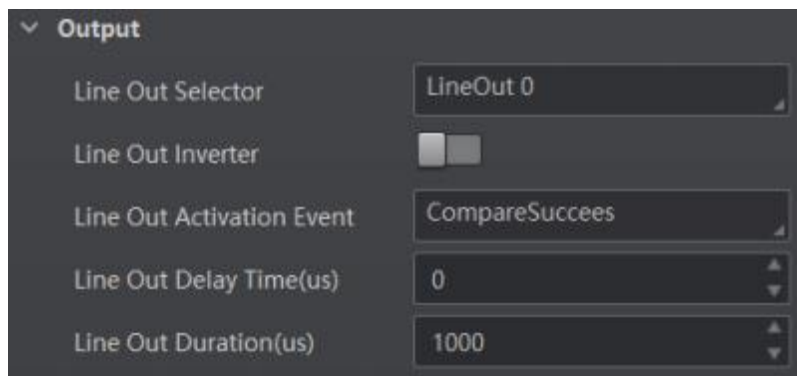

Figure 9-40 Select Compare Success

Select Compare Fail

If you select **Compare Fail** as **Line Out Activation Event**, and you can set its output delay time and duration.

- **Line Out Delay Time:** It sets the delay time for outputting the output signal.
- **Line Out Duration:** It sets the time duration of the output signal.

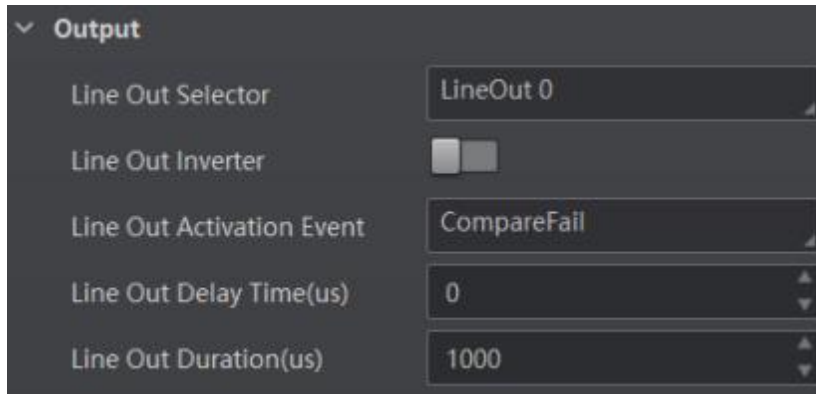

Figure 9-41 Select Compare Fail

Select Command Control IO

If you select **Command Control IO** as **Line Out Activation Event**, and you do not need to set any parameters.

- **Control Start Str**: It sets the start string of command control.
- **Control Stop Str**: It sets the stop string of command control.
- **Line Out Delay Time**: It sets the delay time for outputting the output signal.
- **Line Out Duration**: It sets the time duration of the output signal.

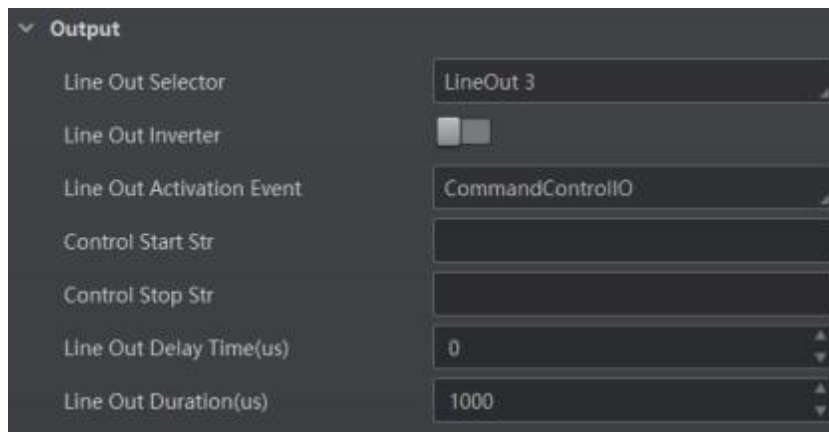

Figure 9-42 Select Command Control IO

9.7.4 Set Buzzer

Note

- Only type VI and type VII devices support buzzer function.
- Make sure that the device is the **Normal** mode before using the buzzer function.

The buzzer is used to indicate the device's operation status, and you can set the buzzer function according to actual demands.

Steps

1. Right click the device in **Device Connection**, and click **Feature Tree**.
 2. Goto **Trigger and IO Control** → **Buzzer Enable**, and enable **Buzzer Enable**.
-

 **Note**

After enabling **Buzzer Enable**, the buzzer beeps three times when the device is powered on, beeps twice when the device reads setting codes successfully, and beeps once when the device reads codes successfully.

3. Set **Buzzer Duration (ms)** and **Buzzer Frequency (hz)** according to actual demands.

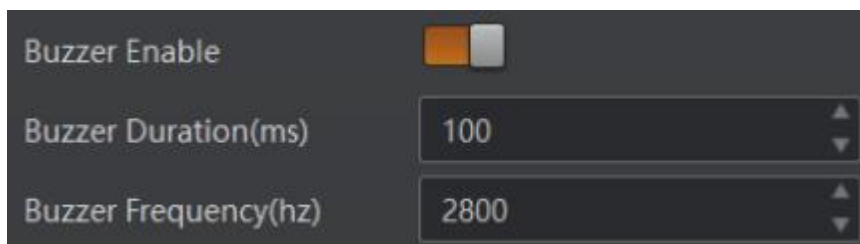

Figure 9-43 Set Buzzer

9.8 Communication Settings

The communication protocol is used to transmit and output code reading result and image. The communication protocol is related to the device modes. With various device modes, the device supports different communication protocols and corresponding parameters.

- If the device's operation mode is **Test** or **Raw**, and it only supports **SmartSDK** protocol and no parameter settings are required.
 - If the device's operation mode is **Normal**, and it supports **SmartSDK**, **TCP Client**, **Serial**, **FTP**, **TCP Server**, **Profinet**, **MELSEC/SLMP**, **Ethernet/IP**, **ModBus**, **UDP**, **Fins** and **USB** communication protocols, and you need to set corresponding parameters.
-

 **Note**

- The supported communication protocols may differ by device models.
 - Type VII device supports **SmartSDK**, **USB** and **Serial** only. Regarding other device types, the device with USB data interface supports **SmartSDK** and **USB** only, and device with fast Ethernet supports all communication protocols apart from **USB**.
 - The specific parameters of communication protocols may differ by device models.
-

9.8.1 Set SmartSDK

If you select **SmartSDK** as the communication protocol, you can configure the following parameters:

Table 9-7 SmartSDK Communication Protocol

| Parameter | Description |
|--------------------------|---|
| SmartSDK Protocol | If enabled, the device will output data via SmartSDK. |
| Encode JPEG Flag | The device will compress images in JPG format after enabling it. |
| Quantity of JPG | It sets the image compression quality, and it ranges from 50 to 99. |

9.8.2 Set TCP Client

If you select **TCP Client** as the communication protocol, you can configure the following parameters:

Table 9-8 TCP Client Communication Protocol

| Parameter | Description |
|---------------------|---|
| TCP Protocol | If enabled, the device will output data via the TCP server. |
| TCP Dst Addr | Enter the IP address of the server that receives data outputted by the code reader. |
| TCP Dst Port | Enter the port No. of the server that receives data outputted by the code reader. |

9.8.3 Set Serial

If you select **Serial** as the communication protocol, you can configure the following parameters:

Table 9-9 Serial Communication Protocol

| Parameter | Description |
|-------------------------|---|
| Serial Protocol | If enabled, the code reader will output data via serial port. |
| Serial Baudrate | The baud rate of the serial port of the PC that receives data. |
| Serial Data Bits | Data bits of the serial port of the PC that receives data.  Note The hexadecimal trigger is supported only when Serial Data Bits is 8. |
| Serial Parity | Parity bits of the serial port of the PC that receives data. |
| Serial Stop Bits | Stop bits of the serial port of the PC that receives data. |

9.8.4 Set FTP

If you select **FTP** as the communication protocol, you can configure the following

parameters:

Table 9-10 FTP Communication Protocol

| Parameter | Description |
|----------------------|--|
| FTP Protocol | If enabled, the code reader will output data via FTP server. |
| FTP Host Addr | IP address of the FTP host. |
| FTP Host Port | Port No. of the FTP host. |
| FTP User Name | User name of the FTP. |
| FTP User PWD | Password of the FTP. |

9.8.5 Set TCP Server

If you select **TCP Server** as the communication protocol, you can configure the following parameters:

Table 9-11 TCP Server Communication Protocol

| Parameter | Description |
|--------------------------|---|
| TCP Server Enable | If enabled, the code reader will output data via TCP server. |
| TCP Server Port | The port No. of the TCP server that receives data outputted by code reader. |

9.8.6 Set Profinet

If you select **Profinet** as the communication protocol, you can configure the following parameters:

Table 9-12 Profinet Communication Protocol

| Parameter | Description |
|-----------------------------|--|
| Profinet Enable | If enabled, the device will output data via Profinet protocol. |
| Profinet Device Name | Enter the name of the code reader, which is used for code reader recognition in Profinet protocol communication. |

9.8.7 Set MELSEC/SLMP

If you select **Melsec/SLMP** as the communication protocol, you can configure the following parameters:

Table 9-13 MELSEC/SLMP Communication Protocol

| Parameter | Description |
|-------------------------------------|--|
| MELSEC Protocol Enable | If enabled, the code reader will output data via MELSEC protocol. |
| MELSEC Server IP | IP address of the Programmable Logic Controller (PLC) connected to the code reader. |
| MELSEC Server Port | Port number of the Programmable Logic Controller (PLC) connected to the code reader. |
| MELSEC Frame Type | Frame type of the MELSEC. |
| MELSEC Network Number | Network number to communicate with. |
| MELSEC Node Number | Node number to communicate with. |
| MELSEC Processor Number | Processor number to communicate with. |
| MELSEC Control Poll Interval | Requested time between successive polls of the control block from the PLC. |
| MELSEC Control Space | It sets storage space of the control area. |
| MELSEC Control Offset | It sets the start offset address of the control area. |
| MELSEC Control Size (Word) | It sets the size of the control area. |
| MELSEC Status Space | It sets storage space of the status area. |
| MELSEC Status Offset | It sets the start offset address of the status area. |
| MELSEC Status Size (Word) | It sets the size of the status area. |
| MELSEC Result Space | It sets storage space of the result area. |
| MELSEC Result Offset | It sets the start offset address of the result area. |
| MELSEC Result Size (Word) | It sets the size of the result area. |
| MELSEC Result Byte Swap | If it is enabled, the client software will swap MELSEC results. |
| MELSEC Result Timeout | It sets the MELSEC result timeout, and the unit is s. |

9.8.8 Set Ethernet/IP

If you select **EthernetIp** as the communication protocol, you can configure the following parameters:

Table 9-14 Ethernet/IP Communication Protocol

| Parameter | Description |
|---------------------------|--|
| Ethernet/IP Enable | If enabled, the code reader will output data via Ethernet/IP protocol. |

9.8.9 Set ModBus

If you select **Modbus** as the communication protocol, you can configure the following parameters:

Table 9-15 ModBus Communication Protocol

| ModBus | Description |
|----------------------------------|---|
| ModBus Enable | If enabled, the code reader will output data via ModBus protocol. |
| ModBus Mode | Select a mode from Server and Client . |
| ModBus Control Space | The value is "holding_register" by default and not editable. |
| ModBus Control Offset | Offset of the control address. The default value is 0. |
| ModBus Control Size | The value is 1 by default. |
| ModBus Status Space | It sets status space and it is "holding_register" by default. |
| ModBus Status Offset | It sets status offset and it is 1 by default. |
| ModBus Status Size | It is 1 by default. |
| ModBus Result Space | It set result space and it is "holding_register" by default. |
| ModBus Result Offset | It is 2 by default. |
| ModBus Result Size | It is 100 by default. |
| ModBus Result Byte Swap | If it is enabled, the client software will swap ModBus results. |
| ModBus Result Timeout (s) | It sets the result timeout of the ModBus protocol. |

9.8.10 UDP

If you select **UDP** as the communication protocol, you can configure the following parameters:

Table 9-16 UDP Communication Protocol

| Parameter | Description |
|----------------------------|--|
| UDP Protocol Enable | If enabled, the code reader will output data via User Datagram Protocol (UDP). |
| UDP Dst IP | The IP address of the PC receiving the output data. |
| UDP Dst Port | The port of the PC receiving the output data. |

9.8.11 Fins

If you select **Fins** as the communication protocol, you can configure the following parameters:

Table 9-17 Fins Communication Protocol

| Parameter | Description |
|--|---|
| Fins Enable | If enabled, the code reader will output data via TCP/UDP FIN. |
| Fins Server IP | It sets the server IP of Fins. |
| Fins Server Port | It is 9600 by default. |
| Fins Control Poll Interval (ms) | It sets how often read data. |
| Fins Control Space | It sets storage space of the control area. |
| Fins Control Offset | It sets the start offset address of the control area. |
| Fins Control Size (Word) | It sets the size of the control area. |
| Fins Status Space | It sets storage space of the status area. |
| Fins Status Offset | It sets the start offset address of the status area. |
| Fins Status Size (Word) | It sets the size of the status area. |
| Fins Result Space | It sets storage space of the result area. |
| Fins Result Offset | It sets the start offset address of the result area. |
| Fins Result Size (Word) | It sets the size of the result area. |
| Fins Result Byte Swap | If it is enabled, the client software will swap Fins results. |
| Fins Result Timeout (s) | It sets the Fins result timeout, and the unit is s. |

9.8.12 USB

If you select **USB** as the communication protocol, you can configure the following parameters:

Table 9-18 USB Communication Protocol

| Parameter | Description |
|---------------|---|
| USB Enable | If enabled, the code reader will output data via USB. |
| USB Output | It sets the USB output mode, including CDC and HID. |
| USB Baudrate | It is 9600 by default. |
| USB Data Bits | It is 8 by default. |
| USB Parity | It is No Parity by default. |
| USB Stop Bits | It is 1 by default. |

9.9 Data Processing Settings

In **Data Processing**, you can set filter rules for reading codes and other data processing related parameters.

Note

The specific parameters may differ by device models and firmware versions.

9.9.1 Set Filter Rule

You can set rules via **Filter Rule** to filter unwanted codes to improve the reading efficiency.

Normal Filter Mode

If the device's operation mode is normal, trigger mode is on, filter mode is normal, and you can set following parameters according to actual demands:

- **Instant Output Mode Enable:** If enabled, the device will output barcode data immediately once a code is read. If not enabled, the barcode data will be outputted after the device trigger process ends.

Note

The parameter is only available when the running mode is set to Normal mode and the trigger mode is enabled.

- **Min. Output Time(ms) :** Define the minimum time duration (unit: ms) for data output. The duration starts from trigger time. Note: The parameter is only available when the running

mode is set to Normal mode and the trigger mode is enabled.

Note

The parameter is only available when the running mode is set to Normal mode and the trigger mode is enabled.

- **Min. Code Length:** If the length of a barcode is shorter (in terms of the number of characters) than the configured value, the device will NOT parse the barcode.
For example, if you set the value to 6, the device will not parse the barcodes which contain fewer than 6 characters.
-

Note

The valid value of the parameter is from 1 to 256.

- **Max. Code Length:** If the length of a barcode is longer (in terms of the number of characters) than the configured value, the device will NOT parse the barcode.
For example, if you set the value to 9, the device will not parse the barcodes which contain more than 9 characters.
-

Note

The valid value of the parameter is from 1 to 256.

- **Numeral Filter:** If enabled, the device will only parse and read the numeral contents of the barcodes, and the non-numeral contents will be filtered out.
 - **Begin with Specific Character for Result:** enabled, the device will only read the barcodes which begin with a specific character string.
 - **Begins with:** Enter the character string.
 - **Include Specific Character in Barcode:** If enabled, the device will only read the barcodes which include a specific character string.
 - **Character:** Enter the character string.
 - **Exclude Specific Character in Barcode:** If enabled, the device will only read the barcodes without a specific character string.
 - **Character:** Enter the character string.
 - **Remove Duplicate By ROI:** If it is enabled, the device will filter information based on drawn ROIs.
 - **Read Times Threshold:** If the reading results of a barcode is same for the configured times, the barcode will be regarded as valid and its data will be outputted. Or the barcode will be regarded as invalid and its data will not be outputted.
 - **De-duplication Enable By Trigger:** If it is enabled, the repeated code information will be filtered within specific trigger times. You can set trigger times in **De-duplication Windows Size**, and its default value is 1.
 - **De-duplication By ROI:** If it is enabled, the device will filter information based on drawn ROIs.
 - **Code Start Offset Num:** It cuts the specific length of code contents from starting, and the remaining part will be outputted.
 - **Code End Offset Num:** It cuts the specific length of code contents from ending, and the
-

remaining part will be outputted.

Regular Expression Filter Mode

The device supports filtering codes via the regular expression.

Steps

1. Select **Regular Expression** as the **Filter Mode**, and click **Set** in **Regular Expression Filter** to enter regular expression filter settings window.
2. Import local files or add customized filter rules to set the regular expression.
 - Import local files: Click **Import** to import local .xml files, and click **OK** to finish.



Figure 9-44 Regular Expression Filter Settings

- Add customized filter rule: Click **Add** and set related parameters in the popped-up window, and click **OK** after configuring parameters.

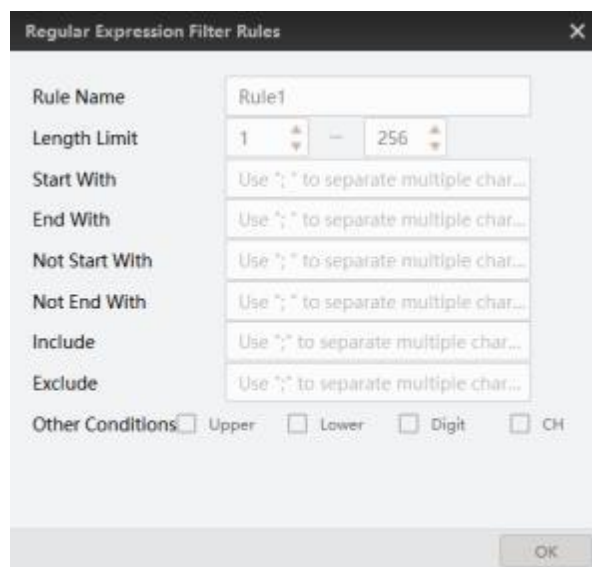







Figure 9-45 Enter Customized Regular Expression Filter Rules

Table 9-19 Filter Rule Parameters

| Parameter | Description |
|------------------|---|
| Rule Name | The default rule name is Rule 1, and you can edit it according to actual demands. |
| Length Limit | It sets the length range of the code, and its upper limit is 256. |
| Start With | <p>It sets the specific start with code. You can use semicolon to separate if there are multiple characters.</p> <p> Note</p> <p>If multiple characters are used, code meeting one of these characters is valid.</p> |
| End With | <p>It sets the specific end with code. You can use semicolon to separate if there are multiple characters.</p> <p> Note</p> <p>If multiple characters are used, code meeting one of these characters is valid.</p> |
| Not Start With | <p>It excludes the specific start with code. You can use semicolon to separate if there are multiple characters.</p> <p> Note</p> <p>If multiple characters are used, code meeting one of these characters is valid.</p> |
| Not End With | <p>It excludes the specific end with code. You can use semicolon to separate if there are multiple characters.</p> <p> Note</p> <p>If multiple characters are used, code meeting one of these characters is valid.</p> |
| Included | <p>It sets the code with specific content. You can use semicolon to separate if there are multiple characters.</p> <p> Note</p> <p>If multiple characters are used, code meeting all these characters is valid.</p> |
| Excluded | <p>It sets the code without specific content. You can use semicolon to separate if there are multiple characters.</p> <p> Note</p> <p>If multiple characters are used, code meeting all these characters is valid.</p> |
| Other Conditions | You can select uppercase, lowercase, digit or Chinese. |

3. After setting filter rule, enter the code in **Code Check** to check if the filter rule is successful.

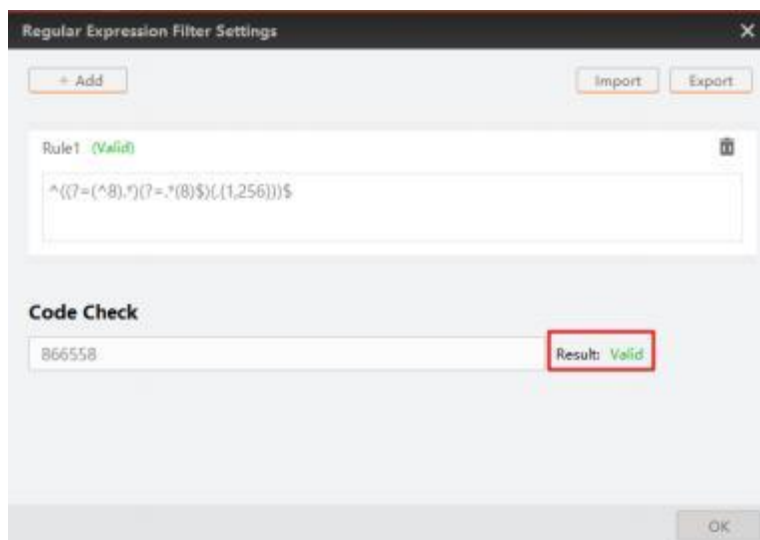

Figure 9-46 Code Check

Note

If the filter rule you configured is correct, the result is valid. Otherwise, it is invalid.

4. (Optional) Click  to delete unwanted filter rules.

5. (Optional) Click **Export** to export configured filter rules to local PC.

Note

The filter rule parameters of the regular expression may differ by device models and firmware versions.

9.9.2 Data Processing Settings

You can configure the contents contained in the output barcode information.

Note

- The actual parameters displayed may vary with different communication protocols. For details about communication settings, refer to **Communication Settings**.
 - The device with USB data interface supports **SmartSDK** and **USB** only, and device with fast Ethernet supports all communication protocols apart from **USB**.
 - The specific parameters and parameter order may differ by the device's operation mode, trigger mode, device models and firmware versions.
-

SmartSDK

- **NoRead Image Index:** It sets the specific image that is outputted when no code information is read. For example, if you set this parameter as 5, and the 5th image will be output.
- **One By One Enable:** If it is enabled, the device will send one piece of code information each time in accordance with the specified interval. You can set the interval via **One By One Interval** and the default value 100 ms.

FTP

When the communication protocol is FTP, set the following parameters of data processing:

- **NoRead Image Index:** It sets the specific image that is outputted when no code information is read. For example, if you set this parameter as 5, and the 5th image will be output.
- **One By One Enable:** If it is enabled, the device will send one piece of code information each time in accordance with the specified interval. You can set the interval via **One By One Interval** and the default value 100 ms.
- **Local Save Picture Mode:** It includes **Off**, **NoRead**, and **Insufficient Code**. You can select **NoRead** to let the device save images when no code is read.
- **Local Picture Type:** Specify the type of pictures saved locally. You can select **JPEG** or **BMP**.
- **Output Retrans Enable:** Enable to allow data re-transmission. Specify the limit of re-transmission attempts in **Output Retrans Number**.
- **FTP Picture Name Format:** Click  to select one or multiple items to be contained in the picture name. The selected items will be displayed in the frame. You can also enter more contents directly in the frame.
- **FTP Transmission Conditions:** Set the condition to upload the data outputted by the device to FTP server.
 - **All:** Always upload the data.
 - **ReadBarcode:** Upload the data only when the barcode is read by the device.
 - **NoReadBarcode:** Upload the data only when no barcode is read by the device.
- **FTP Transmission Result Contain:** Select contents to upload to the FTP server.
 - **JustResult:** Only upload the content of the barcode.
 - **JustPicture:** Only upload the barcode image.
 - **ResultAndPicture:** Upload both the content of the barcode and the barcode image.
- **FTP Time Format:** Select a format type from the drop-down list for the time stamp contained in the file name.

Note

Take YYYYMMDD_HHMMSSFFF as an example, (from the left to the right) YYYY represents year, MM month, DD date, HH hour, MM minute, SS second, FFF millisecond.

TCP Client / Serial / TCP Server / Profinet / MELSEC / EthernetIp / Modbus /

UDP / FINS/ USB

When the communication protocol is TCP Client / Serial / TCP Server / Profinet / MELSEC / EthernetIp / Modbus / UDP / FINS/ USB, set the following parameters of data processing.

Note

Here we use “***” to represent the specific protocol name.

- **NoRead Image Index:** It sets the specific image that is outputted when no code information is read. For example, if you set this parameter as 5, and the 5th image will be output.
- **One By One Enable:** If it is enabled, the device will send one piece of code information each time in accordance with the specified interval. You can set the interval via **One By One Interval** and the default value 100 ms.
- **Local Save Picture Mode:** It includes **Off**, **NoRead**, and **Insufficient Code**. You can select **NoRead** to let the device save images when no code is read.
- ***** Output Format:** Click  to select one or multiple items to be contained in the picture name. The selected items will be displayed in the frame. You can also enter more contents directly in the frame.
- ***** Output Noread Enable:** Enable this to set the default output content if no barcode is read during transmission. Edit the output text in **Output NoRead Text**.
- ***** Output Start Text:** The contents of the start part of the data outputted. You can set the contents as desired.
- ***** Output Stop Text:** The contents of the end part of the data outputted. You can set the contents as desired.
- ***** Output Barcode Enter Character Enable:** Whether to show input character in the data.
- ***** Output Barcode Newline Character Enable:** Whether to show new-line character in the data.

9.10 Set Multicast

The multicast function is used to let multiple devices have the same trigger number when they are acquiring images and analyzing codes at the sametime. When each device sends the trigger number and outputted images to the code reading platform, the platform will integrate the images with the same trigger number as the information of the same package. The main principle of the multicast function is to set one main device among multiple devices, and remaining devices are called sub devices. As the first triggered device, the main devicesends trigger numbers to sub devices each time, and sub devices replace their trigger numbers with received ones so that all devices have the same trigger numbers. Follow the steps below to set multicast function according to actual demands.

Steps

1. Right click the device in **Device Connection**, and click **Feature Tree**.
 2. Goto **Multi Camera Control**, set one device as **Main** in **Multi Camera Mode** according to actual demands.
-

Note

You can set 32 sub devices at most.

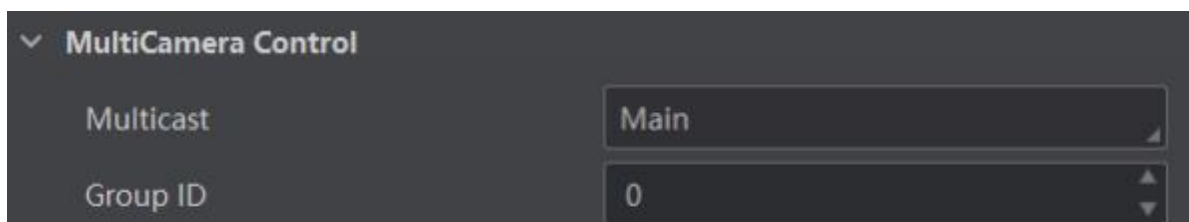

Figure 9-47 Set Multicamera Mode

3. Set **GroupID**.
-

Note

You should set the same GroupID for devices in the same multicast system.

9.11 Main-Sub Networking

When multiple devices acquire images and parse codes at the same time, the main-sub networking function enables multiple devices to work together.

The main principle of main-sub networking is to set one of the multiple devices as the main device (main station), and the other devices as sub devices (sub station). The sub devices send the code results to the main device that integrates or forwards, and sends the code results to the connected PC or client software to realize the collaborative work function of multiple devices.

Before You Start

Make sure that the device mode is **Normal** and **Tigger Mode** is **On** before using this function.

Note

The function of main-sub networking may differ by device models.

Steps

1. Goto **Multi Camera Control**, and select **Multi Station Work Mode** according to actual demands.
 - Off: This function is disabled.
 - Independent: The main device and the sub devices are triggered respectively, and the sub devices send the code reading result to the main device. The main device directly formats

and outputs the sub devices' data according to the formatting rules without data processing. It is mainly used for the scenario of multiple assembly lines.

- Cooperation: The main device and the sub devices use the same trigger, the sub devices send the code reading result to the main device for data processing, and then format and output the data after the fusion of the main and sub devices according to the formatting rules. It is mainly used to the scenario where the field of view is insufficient, and multiple codes are read together to integrate the output. In most cases, this mode is used.
2. Set role for different devices in **Station Role**. **Main** is the main device, and **Sub** is the sub device
-

Note

There is one main device only in the same main-sub networking (same group ID).

3. Set **Station Port** to configure the main station's port number and communicate with the substation.
 4. (Optional) Enable **Client Display Sub Enable** to let the main device display the code reading images from the sub station.
-

Note

The client software of the main device can acquire images after enabling **Client Display Sub Enable**.

5. Set **MS Group ID** ranging from 100 to 200 to configure the main-sub networking group ID.
-

Note

Two-way visiting is not allowing among different network groups.

6. (Optional) View enumerated substation quantity via **Sub Station Total** as a main station role.
 7. (Optional) View sub station information after entering **Query Sub Station ID** as a main station role.
 - Sub Station IP: The IP information of the substation.
 - Sub Station Connect: The connection status of the sub station. 1 stands for normal data transmission. Otherwise, it is disconnected.
 - Sub Station UN: The user name information of the substation.
 - Sub Station MN: The product model information of the substation.
 - Sub Station SN: The serial number of the sub station.
 8. (Optional) View main station information when the **Station Role** is **Sub**.
 - Main Station IP: The IP information of the main station.
 - Main Station Connect: The connection status of the main station. 1 stands for normal data transmission. Otherwise, it is disconnected.
 - Main Station UN: The user name information of the main station.
 - Main Station MN: The product model information of the main station.
 - Main Station SN: The serial number of the main station.
-

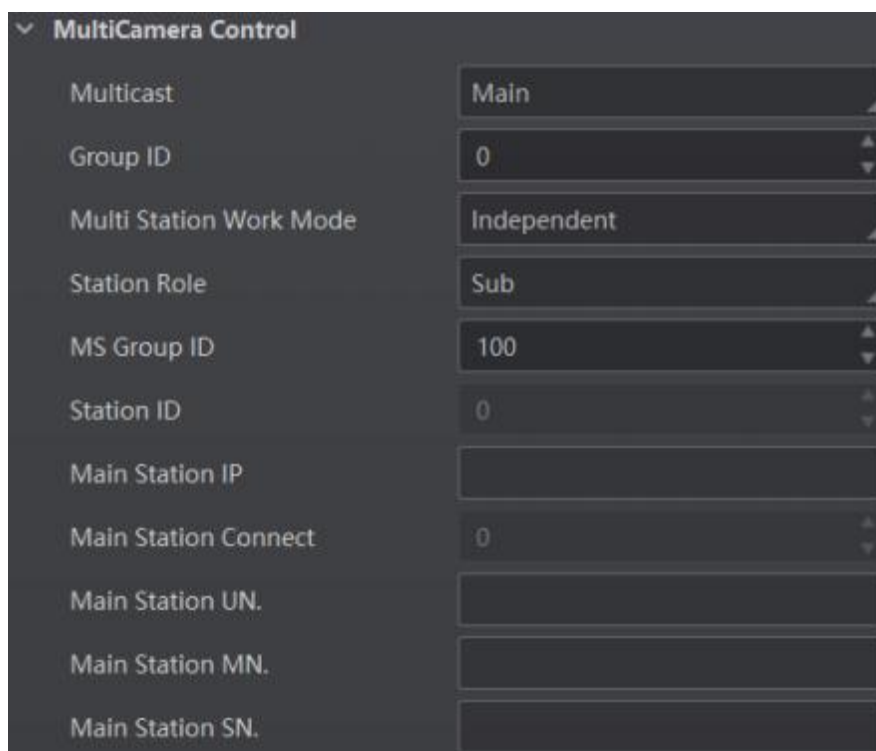

Figure 9-48 Parameters

9.12 Contrast Control Settings

Note

You need to set device's operation mode as normal before using this function.

The contrast control function compares the data that the device reads with preset data and outputs contrast result. The result can be used as the event source of trigger signal, including **Contrast Success** and **Contrast Fail**. This function has two ways to contrast, including regular contrast and consecutive number contrast.

Regular Contrast

The regular contrast requires you to set code contents in advance, and the client software will contrast the data that the device reads with preset contents and outputs comparison result.

Steps

1. Right click the device in **Device Connection**, and click **Feature Tree**.
2. Goto **Contrast Control**, enable **Contrast Enable**, and select **Regular** as **Contrast Rules**.
3. Set **Start Position** that means the starting position of the comparison.
4. Set **Character Number** that means the comparison quantity.
5. Set code contents in **Wildcard String**.

Note

You can use wildcard * and?. * stands for multiple strings you can use, and? stands for one string you can use. * can be used once only and ? can be used many times.

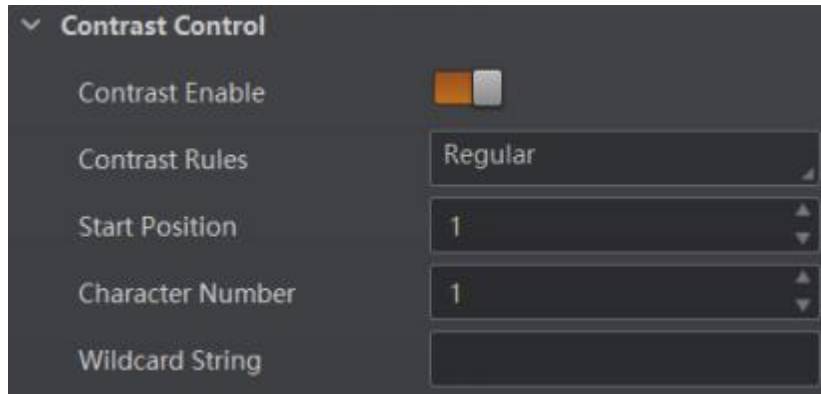

Figure 9-49 Regular Contrast

Consecutive Number Contrast

The consecutive number contrast requires you to set consecutive code rules, and the client software will contrast the data that the device reads with preset rules and outputs contrast result.

Steps

1. Right click the device in **Device Connection**, and click **Feature Tree**.
2. Go to **Contrast Control**, enable **Contrast Enable**, and select **Consecutive Number** as **Compare Rules**.
3. Set **Start Position** that means the starting position of the comparison.
4. Set **Digital Number** that means the comparison quantity.
5. Set **Step** that means the client software will increase or decrease the preset value after each comparison according to the step you set.

Note

- If the preset value after increase or decrease exceeds the digital number you set, and then the preset value will become 0.
 - The base value displays the preset value.
-

6. (Optional) Click **Execute** in **Contrast Reset** to reset comparison. After that, the client software will use the first code it reads as the preset value.

Here we take start position (3), digital number (2) and step (2) as an example to explain the consecutive number comparison:

- If the first code that the device reads is ur96k, and then the preset value is 96. The preset value increases to 98 (96+2).
 - If the second code is yr98kjkfd, and comparison succeeds. The preset value increases to 100 (98+2).
-

- If the third code is kl99fjkd, and comparison fails. The preset value does not increase.
- If the fourth code is kl00djf, and comparison succeeds. The preset value increases to 02 (00+2).

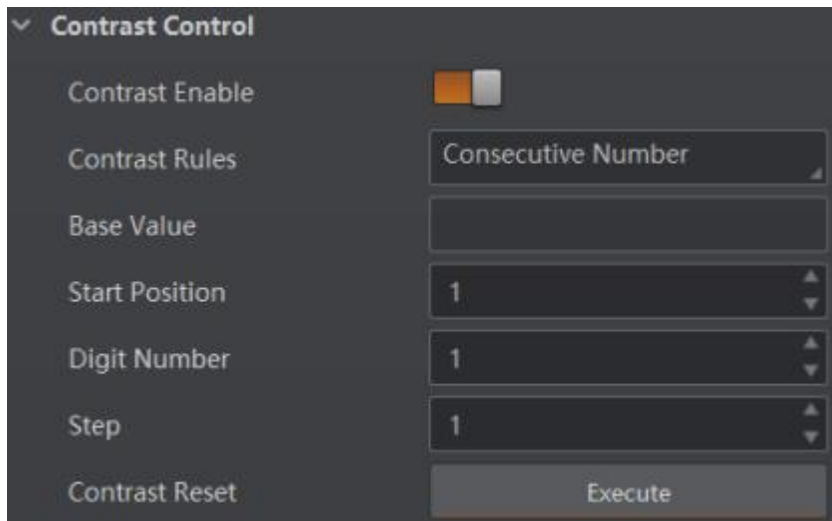

Figure 9-50 Consecutive Number Contrast

9.13 Statistics Information

The statistics information in the feature tree helps you to count data related with code reading.

Note

You need to set device's operation mode as normal before using this function.

Steps

1. Right click the device in **Device Connection**, and click **Feature Tree**.
2. Goto feature tree, find **Statistics Info.**, and select **Statistics Mode**:
 - **All Frames** means the client software will display all data since the device is powered on.
 - **Latest Frames** means the client software will display data of the last 10 frames.
3. View related parameters.
4. (Optional) Click **Execute** in **Reset Statistics** to reset statistics information.

Table 9-20 Parameter Description

| Parameter Name | Description |
|---------------------|---|
| Total Frame Number | The total frame quantity. |
| Read Frame Number | The quantity of frames that have been read codes. |
| Noread Frame Number | The quantity of frames that have not been read codes. |
| Read Rate | It refers to the code reading ratio. |

| Parameter Name | Description |
|------------------|---|
| Algo Time Ave. | The average time of algorithm, and the unit is ms. |
| Algo Time Max. | The max. time of algorithm, and the unit is ms. |
| Algo Time Min. | The min. time of algorithm, and the unit is ms. |
| Read Time Ave. | The average time of code reading, and the unit is ms. |
| Read Time Max. | The max. time of code reading, and the unit is ms. |
| Read Time Min. | The min. time of code reading, and the unit is ms. |
| Reset Statistics | Click Execute to reset statistics information. |

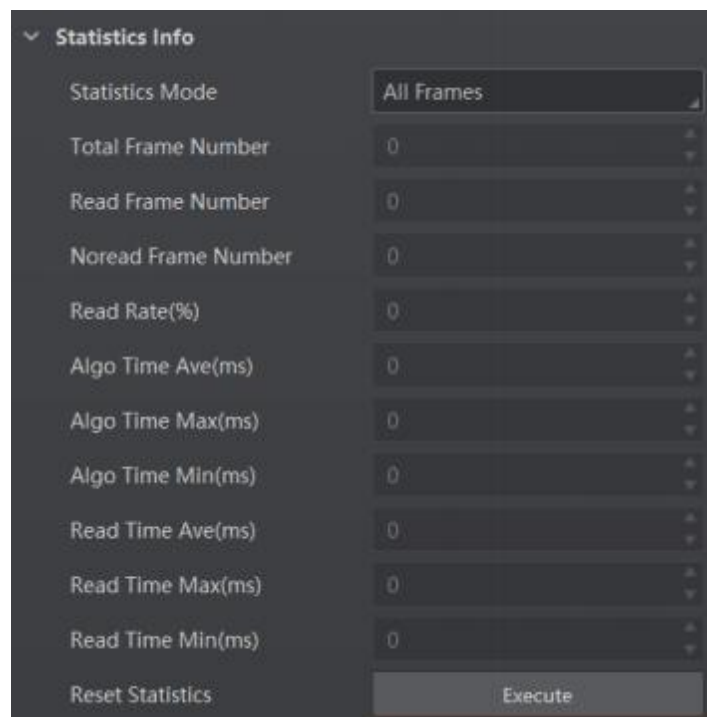

Figure 9-51 Statistics Information

9.14 Diagnose Event Report

The diagnose event report function monitors memory and CPU usage rate, and let you know when there is a crash, higher CPU usage rate, insufficient memory, and other events.

Steps

1. Right click the device in **Device Connection**, and click **Feature Tree**.

2. Goto feature tree, find **Diagnose Event Report**.
3. View relation information.
4. (Optional) Click **Execute** in **Reset Event** to clear all information.

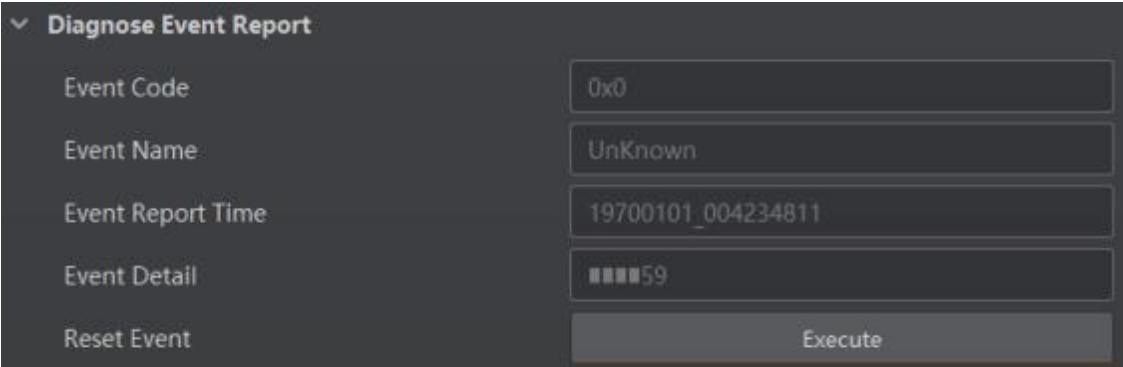

| | |
|-------------------|--------------------|
| Event Code | 0x0 |
| Event Name | UnKnown |
| Event Report Time | 19700101_004234811 |
| Event Detail | #####59 |
| Reset Event | Execute |

Figure 9-52 Event Report

9.15 User Set Customization

In **Configuration Management**, you can set and manage the user set. A user set is a group of parameter values with all the settings needed to control the device, and you can save, load and switch different user sets.

- **Save Settings:** If you have set the device parameters as desired, you can save them into the user set. Goto **Config Management** → **Save Settings**, and click **UserSet1**, **UserSet2**, or **UserSet3** to save the current device settings.
- **Load Settings:** You can load the user set to restore the device to the saved group of parameter values again if required. Go to **Config Management** → **Load Settings**, and click **Default**, **UserSet1**, **UserSet2**, or **UserSet3** to load settings.

Note

The **Default** refers to restore the device parameter settings to the factory ones.

- **Start Settings:** The selected user set will be automatically loaded after the device being powered on. For example, if you select **Default**, the device parameter settings will be restored to the factory settings.

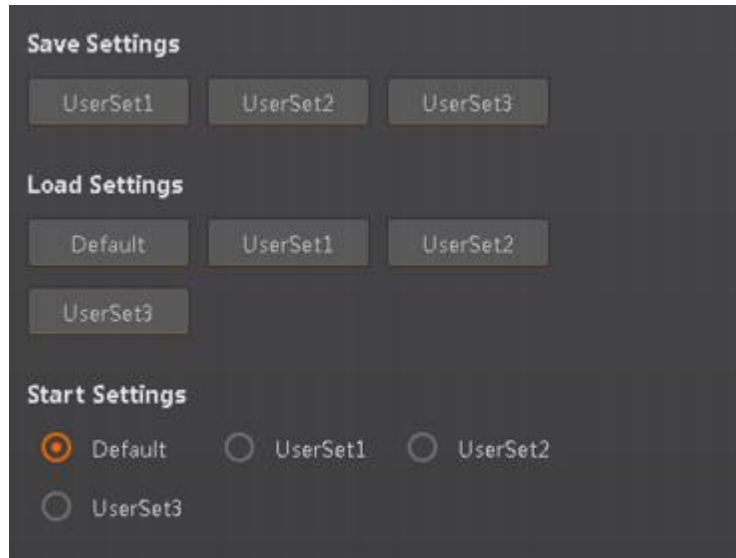

Figure 9-53 User Set Customization

Chapter 10 Setting Codes

10.1 Introduction

The device supports configuring parameters via reading special codes that are called setting codes. Here we introduce common setting codes.

 **Note**

- Type VI and type VII devices support the function of setting codes.
- Before using other setting codes, you need to scan **Enable Setting Codes** first to activate the function of setting codes.



Figure 10-1 Setting Codes Introduction

Table 10-1 Device Mode Description



| No. | Description |
|-----|---|
| 1 | It is the code part of the setting code. After reading this part, the device can finish the corresponding parameter settings. |
| 2 | **stands for the default settings. |
| 3 | It is the content of setting codes. |

Via reading setting codes, the device can set enable/disable settings, set code type, set quantity of code reading, set data processing, set aiming system, set light source, set serial port, etc.

10.2 Enable/Disable Setting Codes

Before using other setting codes, you need to scan **Enable Setting Codes** first to activate the function of setting codes. Scan **Disable Setting Codes** to exit setting codes function.

Table 10-2 Enable/Disable Setting Codes

| Function | Setting Codes | Function | Setting Codes |
|----------------------|---|-----------------------|---|
| Enable Setting Codes |  | Disable Setting Codes |  |







10.3 Set Setting Codes of Code Type













The device can be set what code type to be read via reading specific setting codes. Currently, the device supports Code 39, Code 93, Code 128, CodeBar, ITF 25, ITF 14, EAN 8, EAN 13, UPCA, UPCE, QR Code, Data Matrix, Micro QR, AZTEC, PDF 417, and Han Xin Code.













 **Note**







The supported code types may differ by device models.

Table 10-3 Set Setting Codes of Code Type

| Function | Setting Codes | Function | Setting Codes |
|---------------------|---|----------------------|---|
| Enable All 1D Codes |  | Disable All 1D Codes |  |
| Enable All 2D Codes |  | Disable All 2D Codes |  |
| Enable Code 39 |  | Disable Code 39 |  |

| Function | Setting Codes | Function | Setting Codes |
|-----------------|---|------------------|---|
| Enable Code 128 |  | Disable Code 128 |  |
| Enable Code 93 |  | Disable Code 93 |  |
| Enable CodeBar |  | Disable CodeBar |  |
| Enable ITF 14 |  | Disable ITF 14 |  |
| Enable ITF 25 |  | Disable ITF 25 |  |
| Enable EAN 8 |  | Disable EAN 8 |  |

| Function | Setting Codes | Function | Setting Codes |
|----------------------|---|-----------------------|---|
| Enable EAN 13 |  | Disable EAN 13 |  |
| Enable UCPA |  | Disable UCPA |  |
| Enable UCPE |  | Disable UCPE |  |
| Enable QR Code |  | Disable QR Code |  |
| Enable Data Matrix |  | Disable Data Matrix |  |
| Enable Micro QR Code |  | Disable Micro QR Code |  |

| Function | Setting Codes | Function | Setting Codes |
|---------------------|--|----------------------|--|
| Enable AZTEC Code |  | Disable AZTEC Code |  |
| Enable PDF 417 |  | Disable PDF 417 |  |
| Enable Han Xin Code |  | Disable Han Xin Code |  |

10.4 Set Setting Codes of Code Color

The setting codes of code color include white code on black wall and black code on white wall.

Table 10-4 Set Setting Codes of Code Color

| Function | Setting Codes | Function | Setting Codes |
|--------------------------|---|--------------------------|---|
| Black Code On White Wall |  | White Code On Black Wall |  |

| Function | Setting Codes | Function | Setting Codes |
|---------------|---|----------|---------------|
| Self-Adaptive |  | -- | -- |

Note

- Code 128 and 2D codes can be recognized no matter what kind of code color is configured.
- PDF 417 of white code on blackwall cannot be recognized if the code color is white code or self-adaptive.

10.5 Set Setting Codes of Code Reading Quantity

You can set the device's code reading quantity via scanning the specific setting codes as shown below.

Steps

1. Read setting codes of editing quantity of code reading.



Figure 10-2 Edit Quantity of Code Reading

2. Read the corresponding digital codes according to actual demands.

Note

- The quantity of code reading is related with code reading mode.
- If the code reading mode is batch mode and the quantity of code reading is smaller than or equal to 21, you should scan the digital code of tens digit first, and then scan the single digit. If the quantity of code reading is single digit, the digital code of tens digit is 0. For example, if the quantity of code reading is 12, scan the digital code of 1 first, and then scan 2.
- If the code reading mode is continuous mode, the quantity of code reading is not limited. You should scan the digital code in the first place, and then scan the digital code in the









second place, etc. For example, if the quantity of code reading is 530, scan 5 first, and then 3, and 0 at last.



3. Read the setting codes of saving to save the parameter settings.



Figure 10-3 Setting Codes of Saving

Table 10-5 Digital Codes

| Function | Setting Codes | Function | Setting Codes |
|----------------|---|----------------|---|
| Digital Code 0 |  | Digital Code 1 |  |
| Digital Code 2 |  | Digital Code 3 |  |
| Digital Code 4 |  | Digital Code 5 |  |
| Digital Code 6 |  | Digital Code 7 |  |

| Function | Setting Codes | Function | Setting Codes |
|----------------|---|----------------|---|
| Digital Code 8 |  | Digital Code 9 |  |



10.6 Set Setting Codes of Data Processing

You can set the device's outputted code results via scanning the specific setting codes as shown below.

Steps



1. Read setting codes of enabling prefix or suffix.

Table 10-6 Setting Codes of Enabling Prefix or Suffix

| Function | Setting Codes | Function | Setting Codes |
|---------------|---|----------------|---|
| Enable Prefix |  | Disable Prefix |  |
| Enable Suffix |  | Disable Suffix |  |

2. Read setting codes of editing prefix or editing suffix.

Table 10-7 Setting Codes of Editing Prefix or Suffix

| Function | Setting Codes | Function | Setting Codes |
|-------------|---|-------------|---|
| Edit Prefix |  | Edit Suffix |  |

- Set prefix and suffix characters according to actual demands, find the corresponding hexadecimal code value in ASCII table (see **Appendix A ASCII Table** for details), and read the corresponding digital codes. For example, if the defined prefix and suffix content is *, the corresponding ASCII code is 2a. Use to the device to read the digital code 2 and digital code a in turn.

 **Note**

Up to ten setting codes can be read.

Table 10-8 Setting Codes of atof









| Function | Setting Codes | Function | Setting Codes |
|----------------|---|----------------|---|
| Digital Code a |  | Digital Code b |  |
| Digital Code c |  | Digital Code d |  |
| Digital Code e |  | Digital Code f |  |

Table 10-9 Setting Codes of Data Processing

| Function | Setting Codes | Function | Setting Codes |
|------------------|---|-------------------|---|
| Enable Stop Text |  | Disable Stop Text |  |

| Function | Setting Codes | Function | Setting Codes |
|----------------|---|----------|---------------|
| Edit Stop Text |  | -- | -- |

4. Read the setting codes of saving to save the parameter settings.











Figure 10-4 Setting Codes of Saving

10.7 Set Setting Codes of Aiming System

The aiming system is used to locate codes in the field of view to help read codes easily. The setting codes of aiming system can enable, disable, delay or set delay time of the aiming system.

Table 10-10 Set Setting Codes of Aiming System

| Function | Setting Codes | Function | Setting Codes |
|----------------------------|---|-----------------------------|---|
| Enable Aiming System |  | Disable Aiming System |  |
| Enable Aiming System Delay |  | Disable Aiming System Delay |  |

| Function | Setting Codes | Function | Setting Codes |
|--------------------|---|---------------------|---|
| Set Delay Time 1 s |  | Set Delay Time 2 s |  |
| Set Delay Time 5 s |  | Set Delay Time 10 s |  |



10.8 Set Setting Codes of Light Source

The setting codes of light source can enable or disable the light source, set polling interval, etc. After enabling **Light Polling**, you can let red and white light sources polling alternately in accordance with configured interval when code reading succeeds or before ending trigger.

Note

- By default, the polling interval is 2 s.
- The supported setting codes of light source may differ by device models.

Table 10-11 Set Setting Codes of Light Source

| Function | Setting Codes | Function | Setting Codes |
|--------------------|---|---------------------|---|
| Enable White Light |  | Disable White Light |  |





10.9 Set Setting Codes of Buzzer

The setting codes of buzzer can enable or disable the buzzer function, set its duration, etc.

Note

The supported setting codes of buzzer may differ by device models.

Table 10-12 Set Setting Codes of Buzzer

| Function | Setting Codes | Function | Setting Codes |
|---|--|---|---|
| Enable Buzzer When Reading Codes |  | Disable Buzzer When Reading Codes |  |
| Set Buzzer Duration 50 ms When Reading Codes |  | Set Buzzer Duration 100 ms When Reading Codes |  |
| Set Buzzer Duration 150 ms When Reading Codes |  | -- | -- |



10.10 Set Setting Codes of USB Communication



The setting codes of USB communication can enable or disable the USB communication function, set baud rate, etc.

 **Note**

Only the USB type device supports the USB communication.

Table 10-13 Set Setting Codes of USB Communication

| Function | Setting Codes | Function | Setting Codes |
|--------------------------|---|---------------------------|---|
| Enable USB Communication |  | Disable USB Communication |  |

| Function | Setting Codes | Function | Setting Codes |
|----------------------------|---|----------------------------|---|
| USB HID Communication Mode |  | USB CDC Communication Mode |  |







10.11 Set Setting Codes of Serial Port







The setting codes of serial port can enable or disable serial port function, set the baud rate, parity bit, and stop bit.

 **Note**

Only the fast Ethernet type device supports serial port function.

Table 10-14 Set Setting Codes of Serial Port





| Function | Setting Codes | Function | Setting Codes |
|-----------------------------|---|------------------------------|---|
| Enable Serial Port Function |  | Disable Serial Port Function |  |
| Set Baud Rate as 4800 |  | Set Baud Rate as 9600 |  |
| Set Baud Rate as 19200 |  | Set Baud Rate as 38400 |  |

| Function | Setting Codes | Function | Setting Codes |
|------------------------|---|-------------------------|--|
| Set Baud Rate as 57600 |  | Set Baud Rate as 115200 |  |
| Set None Parity |  | Set Odd Parity |  |
| Set Even Parity |  | Set Stop Bit 1 |  |
| Set Stop Bit 2 |  | | |

10.12 Set Setting Codes of Sending Device Information

The device can send its information to the PC via reading specific setting codes, and the device information includes name, version, algorithm version, hardware version, serial number, etc.



Table 10-15 Set Setting Codes of Sending Device Information



| Function | Setting Codes | Function | Setting Codes |
|----------------------|--|-----------------------|---|
| Send Device Name |  | Get Device Version |  |
| Get Hardware Version |  | Get Algorithm Version |  |
| Get Serial Number |  | -- | -- |

10.13 Set Setting Codes of Trigger

The setting codes of trigger can let the device switch the trigger mode, including pressing trigger switch, self-trigger, response trigger, and support disabling trigger mode.

Table 10-16 Set Setting Codes of Trigger



| Function | Setting Codes | Function | Setting Codes |
|----------------------|---|------------------|---|
| Disable Trigger Mode |  | Response Trigger |  |

| Function | Setting Codes | Function | Setting Codes |
|------------------|--|--------------------|---|
| Self-Trigger |  | Auto Run |  |
| High Sensitivity |  | Middle Sensitivity |  |
| Low Sensitivity |  | -- | -- |

10.14 Set Setting Codes of Management

The setting codes of management can save or initialize user parameters, and restart the device.

Table 10-17 Set Setting Codes of Management

| Function | Setting Codes | Function | Setting Codes |
|----------|---|----------------------------|---|
| Save |  | Initialize User Parameters |  |

| Function | Setting Codes | Function | Setting Codes |
|----------------|---|----------|---------------|
| Restart Device |  | -- | -- |

Chapter 11 Device Maintenance

11.1 Update Firmware

The device supports updating firmware via the client software.

Note

- Disconnect the device with client software.
 - Please use the firmware package of the corresponding device model for upgrading.
 - Do not power off the device or disconnect network during upgrading.
 - The device will reboot automatically after updating the firmware.
-

Steps

1. Select the device to be updated in the device list, and right click the device.
 2. Click **Firmware Update**.
 3. Click  to select update file from local PC, and click **Update** to update firmware.
-

Note

You can also goto **Tool** → **Firmware Updater** to update firmware.

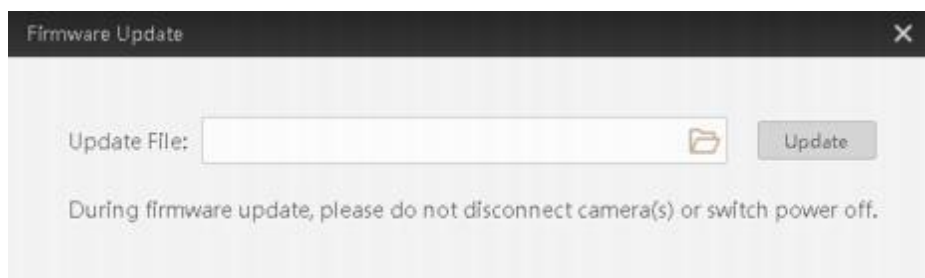

Figure 11-1 Update Firmware

11.2 Set Time

After enabling NTP time synchronization, the device will synchronize time according to the configured interval.

Steps

1. Goto **Config Management**, and find **Timing**.
 2. Click **Setting** and enable **NTP Enable**.
 3. Set parameters according to actual demands.
-

Note

Configure NTP server settings before using NTP time synchronization function.

4. Click **OK** after settings.



Figure 11-2 Set NTP Timing

11.3 Enable Device Auto Work

This function allows the device to automatically enter the operation status after being powered on.

You can go to **Config Management** → **Device Auto Work Enable**, and enable **Device Auto Work Enable**.

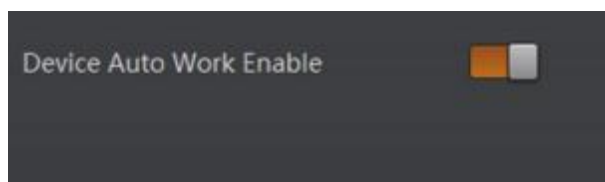

Figure 11-3 Enable Device Auto Work

11.4 Reboot Device

You can reboot the device via client software in 2 ways. Goto **Config Management**, and click **Restart Device**. Or, you can select the device to be rebooted in the device list, right click the device, and click **Device Reset**.

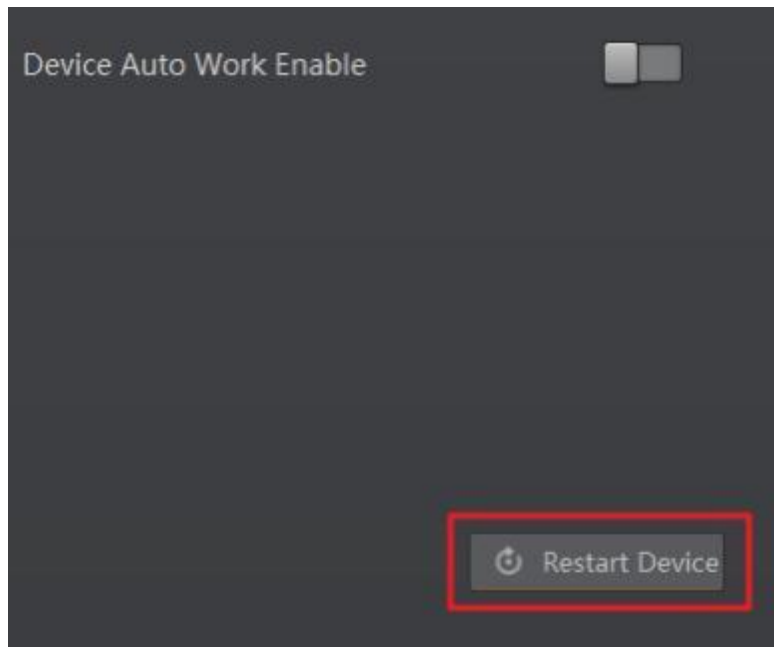

Figure 11-4 Reboot Device

Chapter 12 FAQ (Frequently Asked Question)

12.1 Why there is no device listed after I run the IDMVS client software?

Problem

Run IDMVS client, there is no listed device.

Reason

- The device is powered off.
- Network exception.

Solution

- Check the device's power connection (observe whether the PWR indicator is solid green) to make sure the device is powered up normally.
- Check the network connection (the LNK indicator is flashing green if the network exception occurs) to make sure the device can be connected to the network normally, and make sure that the PC and the device are in the same network segment.

12.2 Why the image is very dark?

Problem

All black or too dark during live view.

Reason

- Insufficient brightness of light source.
- Too small value of exposure and gain.

Solution

- Increase the brightness of light source appropriately, or change to a brighter one.
- Increase exposure and gain appropriately.

12.3 Why the image's frame rate is very low in the live view?

Problem

Image incoherent/low frame rate/image tearing when adjusting images.

Reason

Network circuitry speed is not 100 Mbps.

Solution

Check whether the network transit speed is 100 Mbps or not.

12.4 Why there is no image in the live view?

Problem

No image in the live view.

Reason

- Enabled trigger mode, but there is no trigger signal.
- Network circuitry speed is not 100 Mbps.

Solution

- Sent the trigger signal to the device, or disable the trigger mode.
- Check whether the network circuitry speed is 100 Mbps or not.

Appendix A ASCII Table

Note

The USB type device supports the red color character only regarding setting prefix and suffix characters.

Table A-1 ASCII Table

| Character | Value | Character | Value | Character | Value | Character | Value |
|-----------|-------|-----------|-------|-----------|-------|-----------|-------|
| NUL | 0 | (SPACE) | 20 | @ | 40 | ` | 60 |
| SOH | 1 | ! | 21 | A | 41 | a | 61 |
| STX | 2 | " | 22 | B | 42 | b | 62 |
| ETX | 3 | # | 23 | C | 43 | c | 63 |
| EOT | 4 | \$ | 24 | D | 44 | d | 64 |
| ENQ | 5 | % | 25 | E | 45 | e | 65 |
| ACK | 6 | & | 26 | F | 46 | f | 66 |
| BEL | 7 | ' | 27 | G | 47 | g | 67 |
| BS | 8 | (| 28 | H | 48 | h | 68 |
| HT | 9 |) | 29 | I | 49 | i | 69 |
| LF/NL | 0a | * | 2a | J | 4a | j | 6a |
| VT | 0b | + | 2b | K | 4b | k | 6b |
| FF/NP | 0c | , | 2c | L | 4c | l | 6c |
| CR | 0d | - | 2d | M | 4d | m | 6d |
| SO | 0e | . | 2e | N | 4e | n | 6e |
| SI | 0f | / | 2f | O | 4f | o | 6f |
| DLE | 10 | 0 | 30 | P | 50 | p | 70 |
| DC1/XON | 11 | 1 | 31 | Q | 51 | q | 71 |
| DC2 | 12 | 2 | 32 | R | 52 | r | 72 |
| DC3/XOFF | 13 | 3 | 33 | S | 53 | s | 73 |
| DC4 | 14 | 4 | 34 | T | 54 | t | 74 |
| NAK | 15 | 5 | 35 | U | 55 | u | 75 |

ID2000 Series Industrial Code Reader User Manual

| Character | Value | Character | Value | Character | Value | Character | Value |
|-----------|-------|-----------|-------|-----------|-------|-----------|-------|
| SYN | 16 | 6 | 36 | V | 56 | v | 76 |
| ETB | 17 | 7 | 37 | W | 57 | w | 77 |
| CAN | 18 | 8 | 38 | X | 58 | x | 78 |
| EM | 19 | 9 | 39 | Y | 59 | y | 79 |
| SUB | 1A | : | 3A | Z | 5A | z | 7A |
| ESC | 1B | ; | 3B | [| 5B | { | 7B |
| FS | 1C | < | 3C | \ | 5C | | 7C |
| GS | 1D | = | 3D |] | 5D | } | 7D |
| RS | 1E | > | 3E | ^ | 5E | ~ | 7E |
| US | 1F | ? | 3F | _ | 5F | DEL | 7F |